

## Exhibit C

*To the Complaint captioned*

*Bullseyebore Inc. v. Landbase Trading Co., Ltd. et al*



US007992311B2

(12) **United States Patent**  
**Cerwin**

(10) **Patent No.:** **US 7,992,311 B2**  
(45) **Date of Patent:** **Aug. 9, 2011**

(54) **ROTARY BORING TOOL ALIGNMENT AND DEPTH INDICATION SYSTEM**

(76) Inventor: **John Cerwin**, Gurnee, IL (US)

(\* ) Notice: Subject to any disclaimer, the term of this patent is extended or adjusted under 35 U.S.C. 154(b) by 169 days.

(21) Appl. No.: **12/426,191**

(22) Filed: **Apr. 17, 2009**

(65) **Prior Publication Data**

US 2009/0260239 A1 Oct. 22, 2009

**Related U.S. Application Data**

(60) Provisional application No. 61/045,611, filed on Apr. 17, 2008, provisional application No. 61/050,239, filed on May 4, 2008.

(51) **Int. Cl.**

**G01B 11/27** (2006.01)  
**G01B 11/00** (2006.01)  
**B23B 49/00** (2006.01)

(52) **U.S. Cl.** ..... **33/286; 33/DIG. 21**

(58) **Field of Classification Search** ..... 33/227, 33/263, 278, 279, 280, 626, 638, 642, 644, 33/DIG. 21; 408/16; 356/399, 626, 631  
See application file for complete search history.

(56) **References Cited**

U.S. PATENT DOCUMENTS

2,855,679 A 11/1955 Gibble  
2,822,615 A 9/1956 Durst et al.  
3,117,480 A \* 1/1964 Peddinghaus ..... 83/520  
3,130,633 A \* 4/1964 Rantsch ..... 356/144  
3,864,839 A 2/1975 Wolf  
4,078,869 A 3/1978 Honeycutt

4,154,001 A 5/1979 Serafin  
4,222,175 A 9/1980 Bernicky  
4,564,322 A 1/1986 Stapley  
4,785,544 A 11/1988 Heinsius et al.  
4,968,146 A \* 11/1990 Heizmann et al. .... 356/623  
6,137,579 A \* 10/2000 Reilley ..... 356/399  
6,328,505 B1 \* 12/2001 Gibble ..... 408/16  
6,342,946 B1 \* 1/2002 Holstein ..... 356/152.1  
6,499,219 B1 12/2002 Wightman  
6,565,227 B1 5/2003 Davis  
6,583,869 B1 \* 6/2003 Sheridan ..... 356/153  
6,587,184 B2 7/2003 Wursch  
6,681,869 B2 1/2004 Wursch  
6,692,200 B2 2/2004 Peterson  
6,937,336 B2 8/2005 Garcia et al.  
7,164,474 B2 1/2007 Arntson et al.  
7,200,516 B1 \* 4/2007 Cowley ..... 702/151  
7,243,440 B2 7/2007 DeKeyser  
7,331,113 B1 2/2008 Patrick et al.  
7,375,361 B2 \* 5/2008 Turner et al. .... 250/559.3  
2004/0093749 A1 5/2004 Wu  
2004/0136795 A1 \* 7/2004 Chen ..... 408/16  
2004/0136796 A1 \* 7/2004 Chen ..... 408/16  
2005/0132589 A1 \* 6/2005 Johnson ..... 33/286  
2007/0030486 A1 \* 2/2007 Gelbart ..... 356/399  
2007/0065242 A1 3/2007 Skradski et al.

FOREIGN PATENT DOCUMENTS

DE 2838968 3/1980  
DE 4336730 A1 \* 5/1995  
JP 2002-205285 7/2002

\* cited by examiner

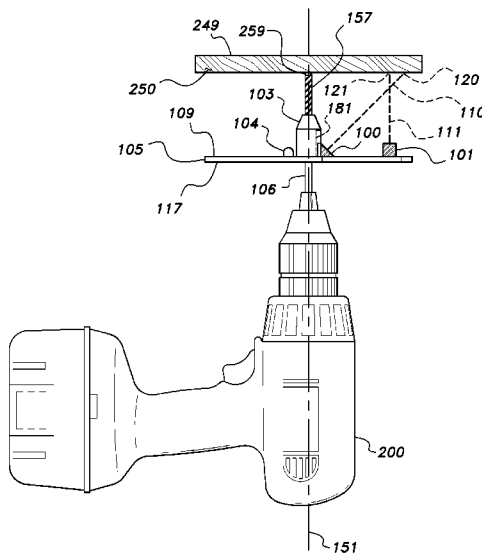
*Primary Examiner* — R. Alexander Smith

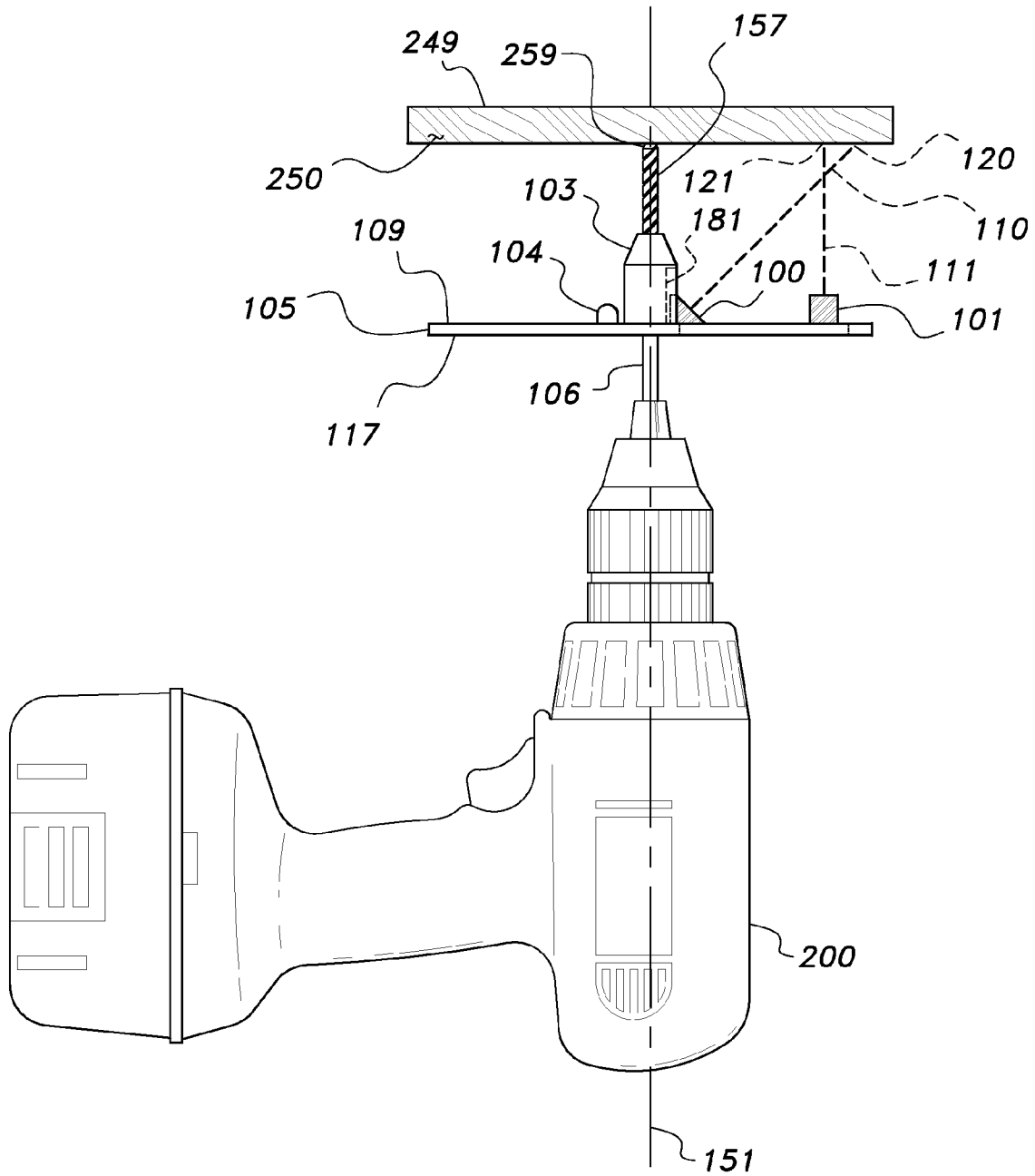
(74) *Attorney, Agent, or Firm* — Christopher Wood; Daniel Eisenberg; Premier Law Group, PLLC

(57) **ABSTRACT**

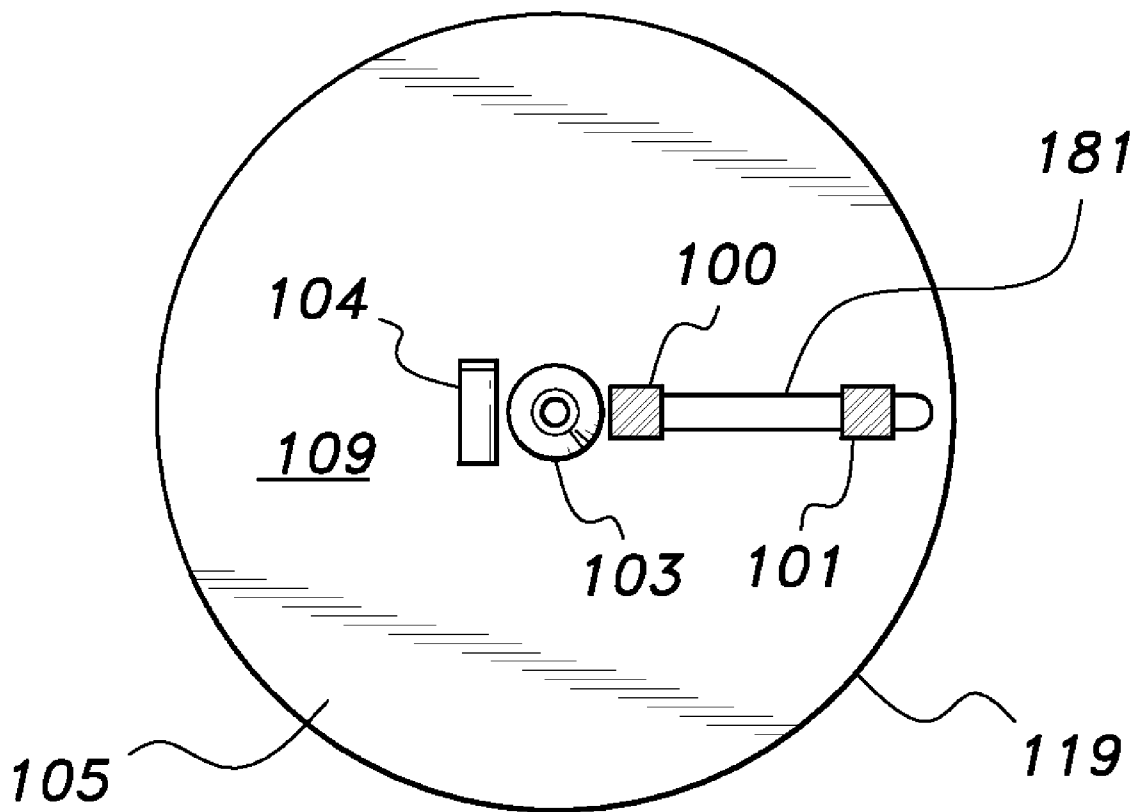
A system for a rotary boring tool that enables a user of the tool to align the tool perpendicularly with respect to a work surface of a work piece. In one embodiment the system enables a user to gauge distance or depth drilled into the work piece.

**10 Claims, 28 Drawing Sheets**

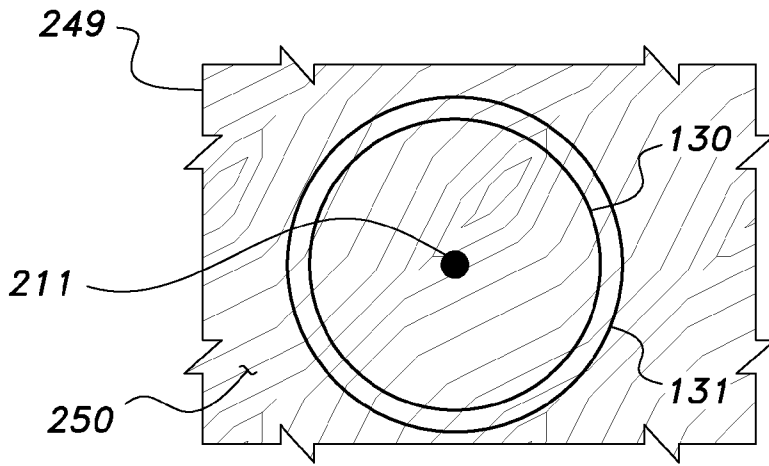




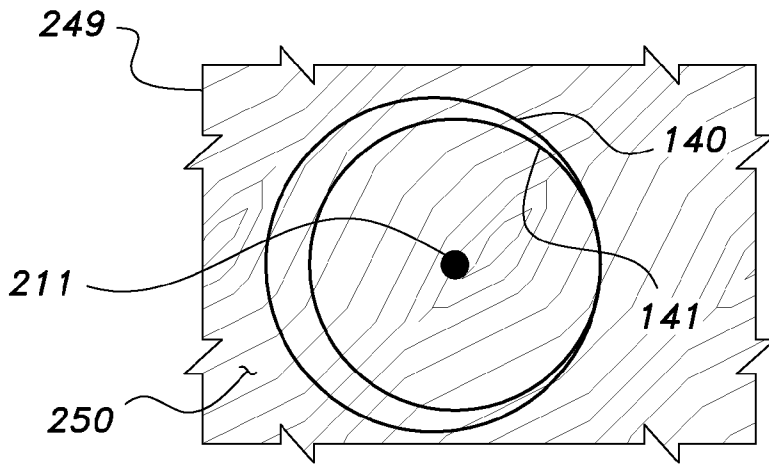
**FIG. 1A**



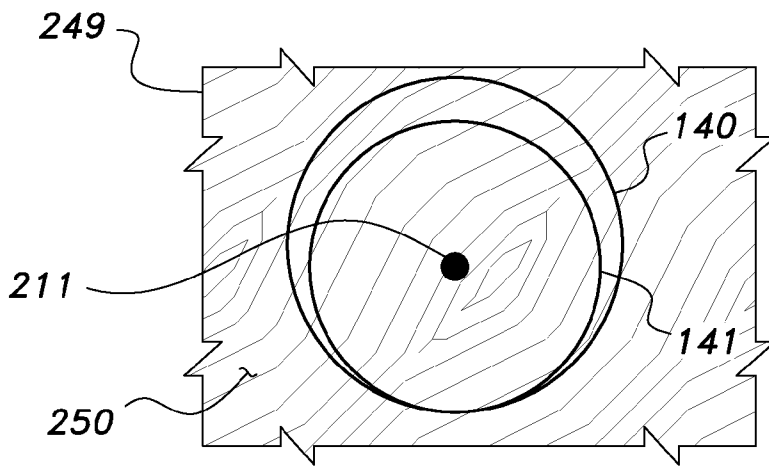
**FIG. 1B**



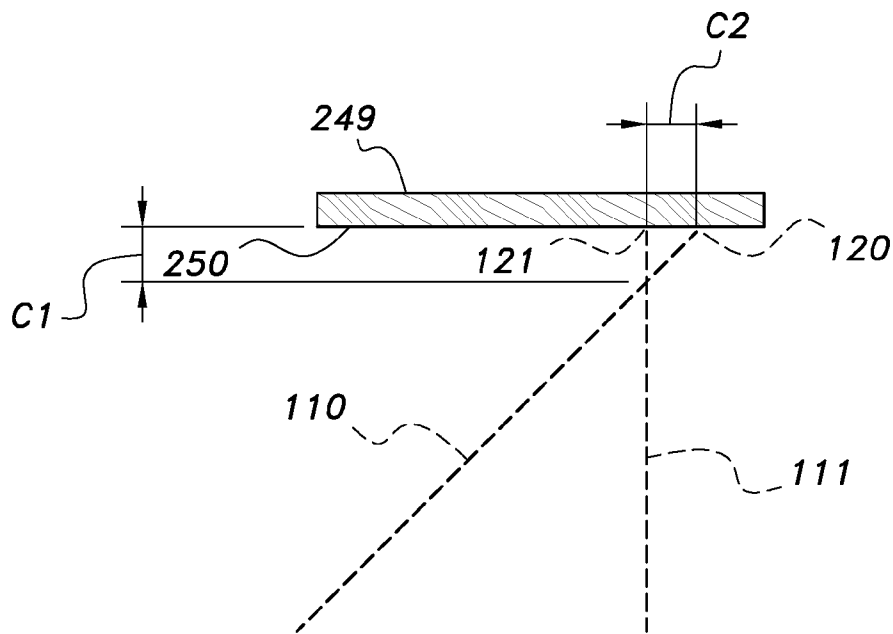
**FIG. 2A**



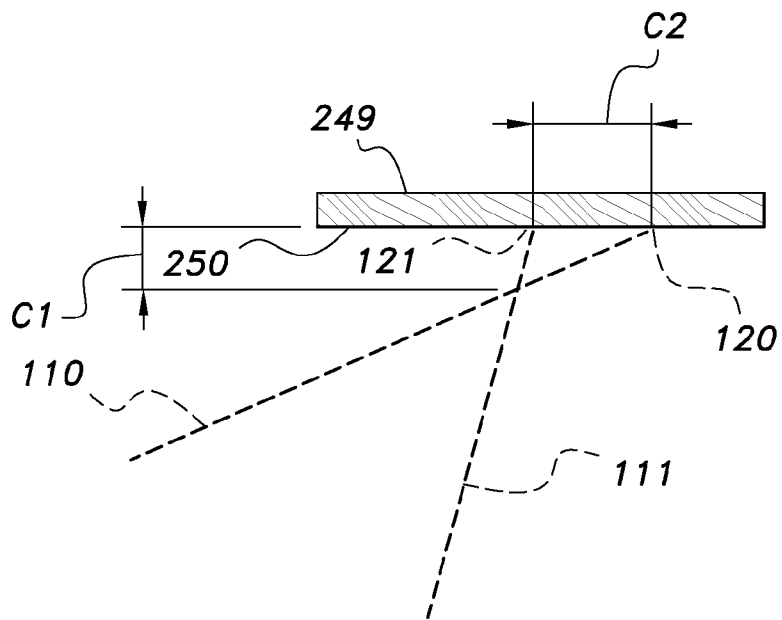
**FIG. 2B**



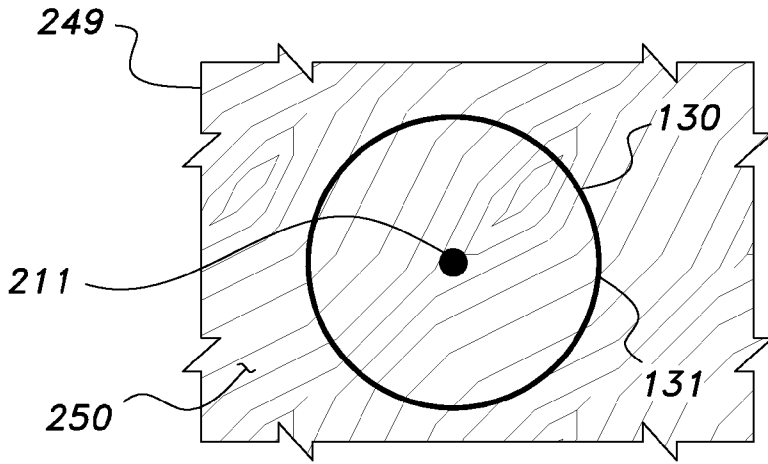
**FIG. 2C**



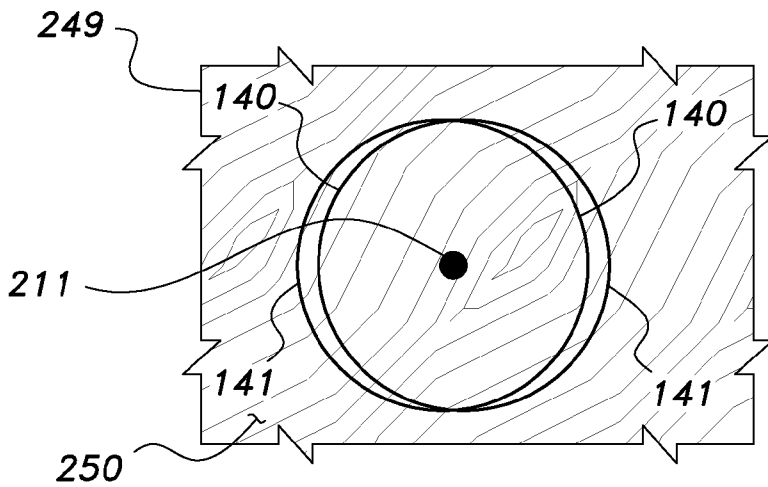
**FIG. 3A**



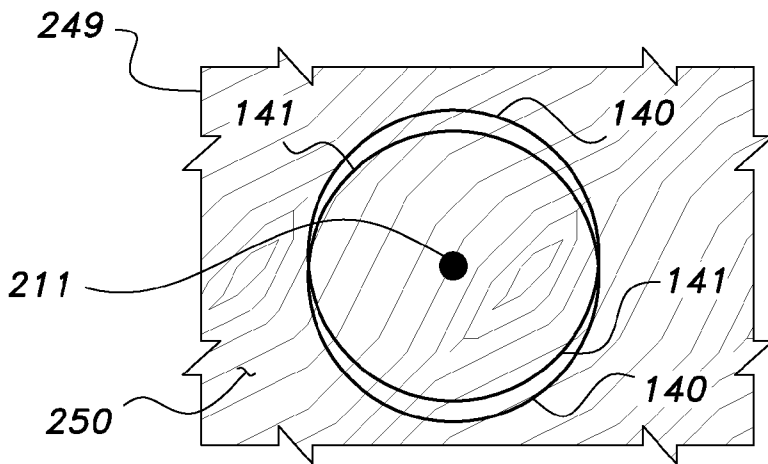
**FIG. 3B**



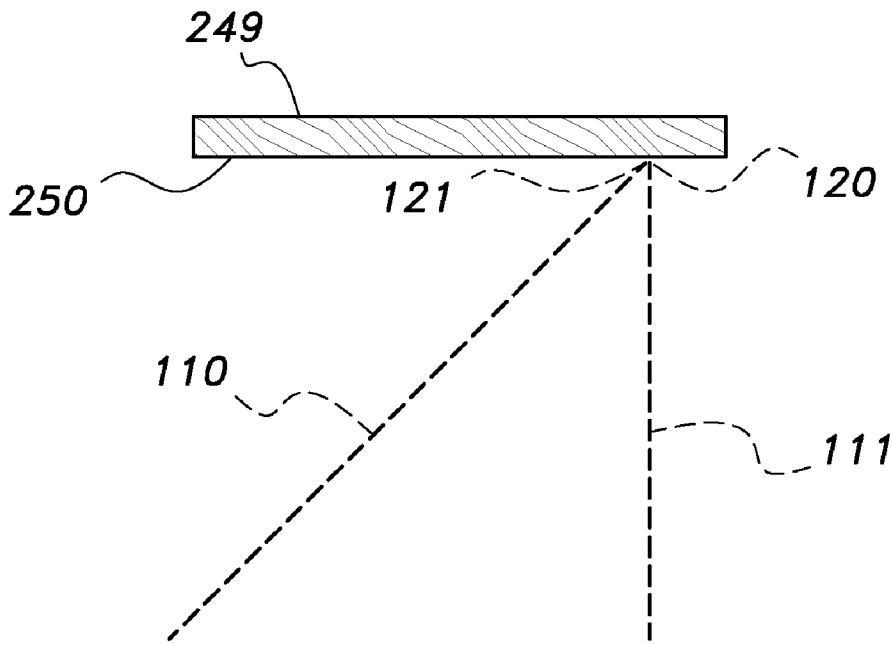
**FIG. 4A**



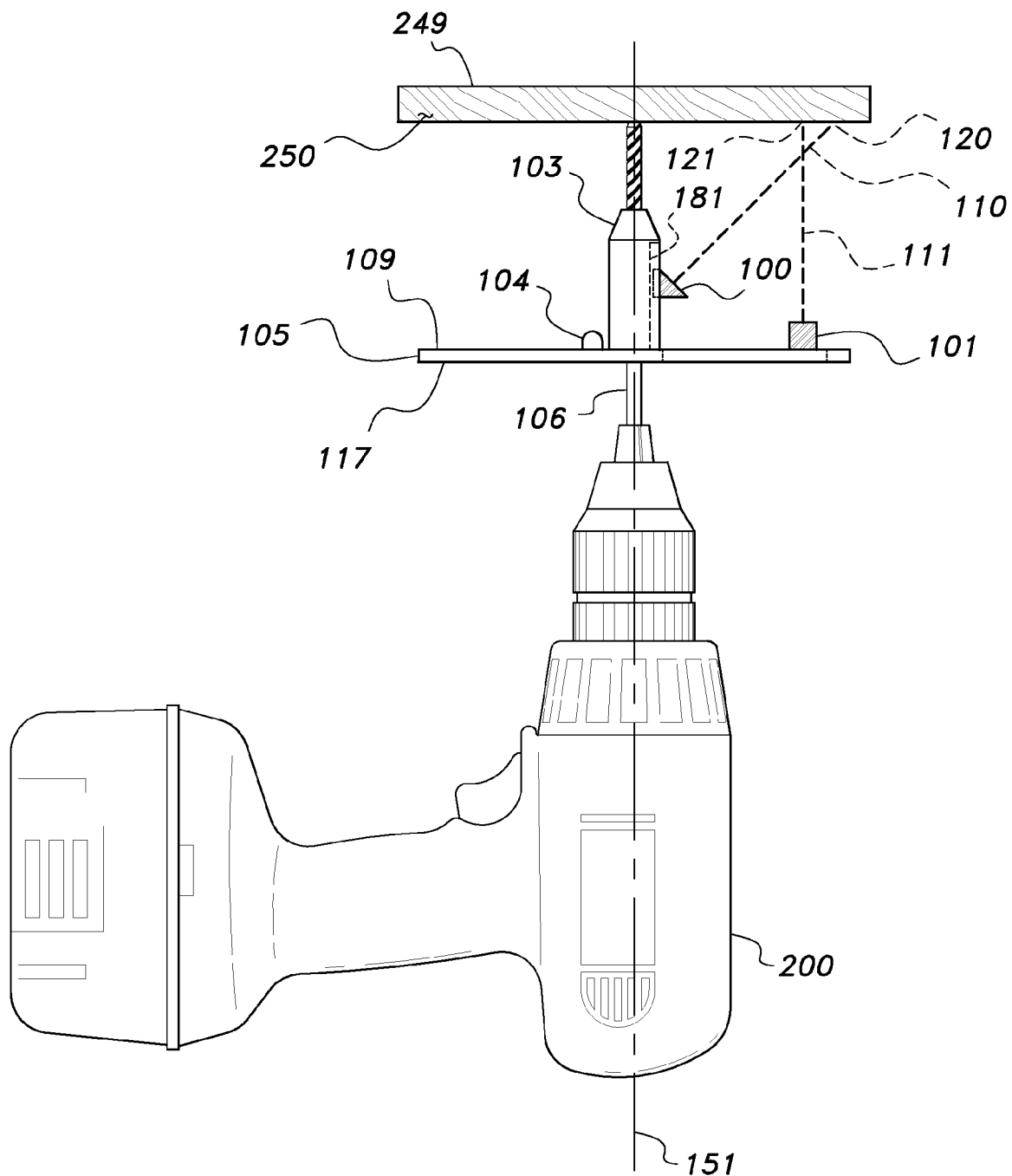
**FIG. 4B**



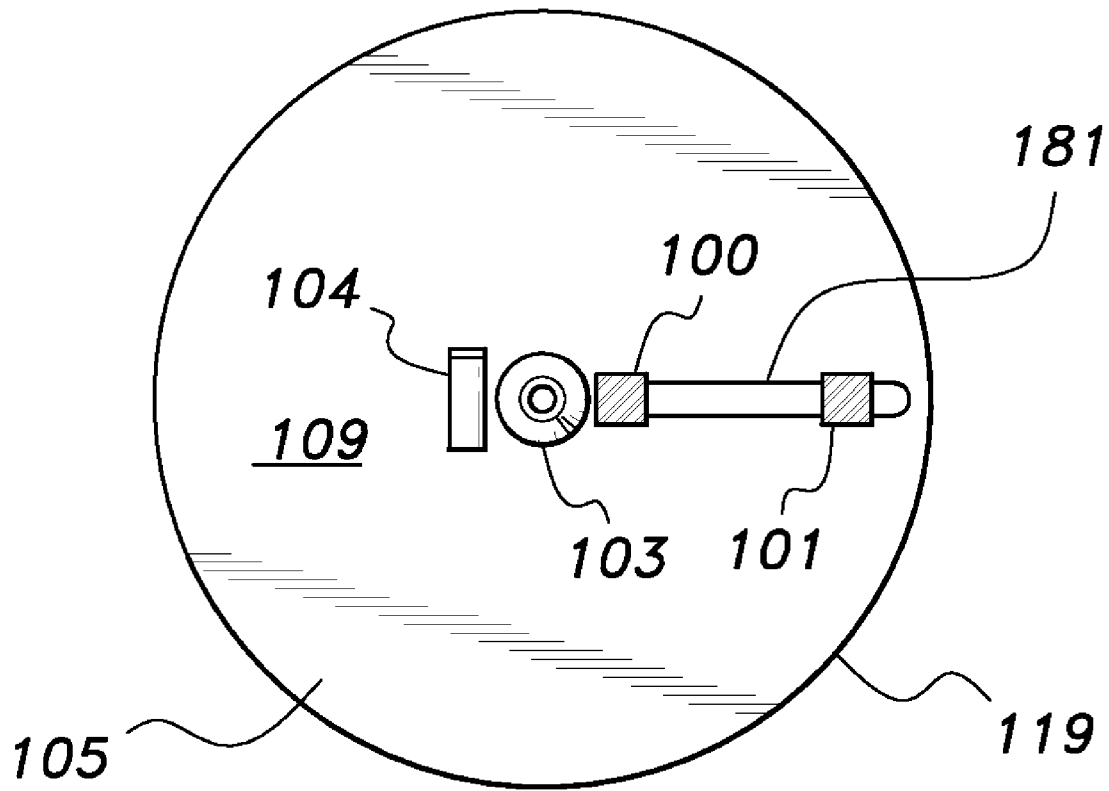
**FIG. 4C**



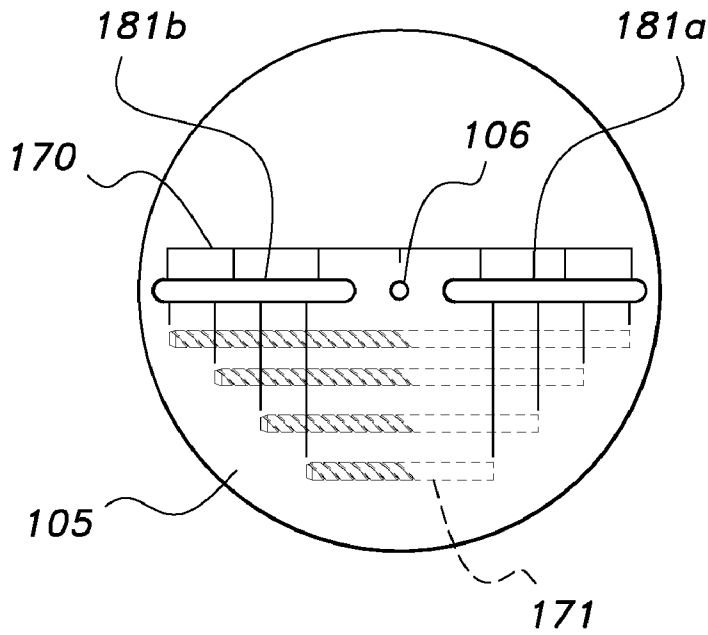
**FIG. 4D**



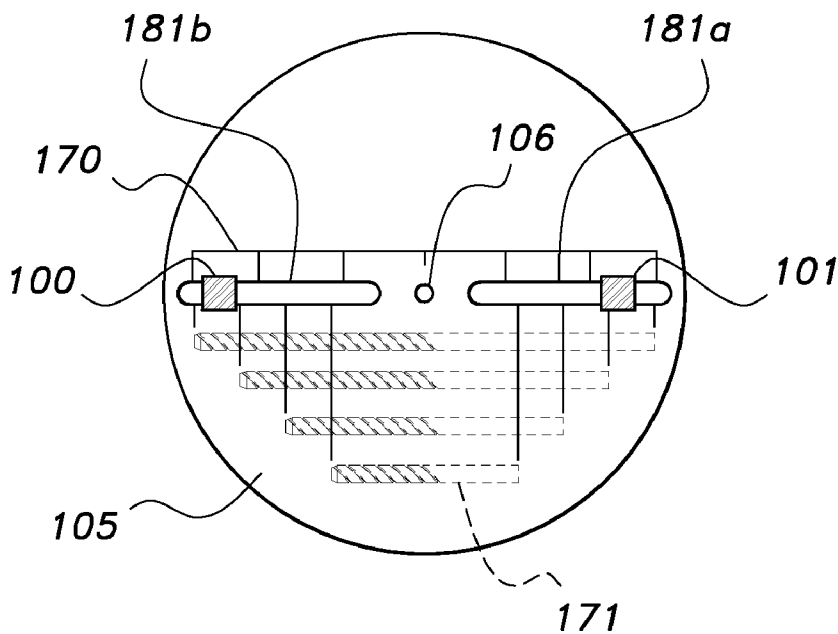
**FIG. 5A**



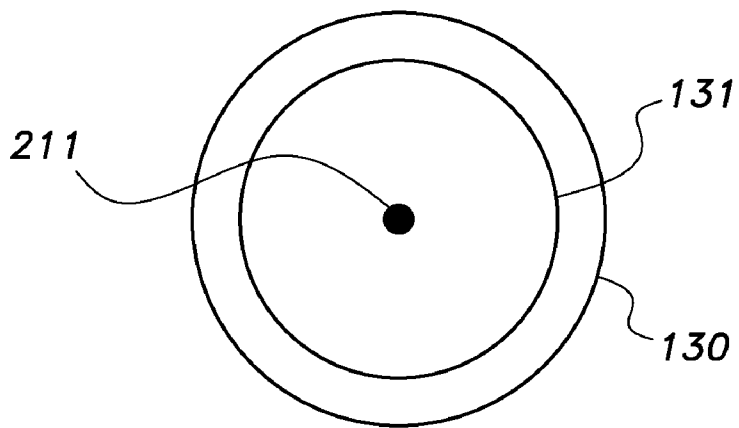
**FIG. 5B**



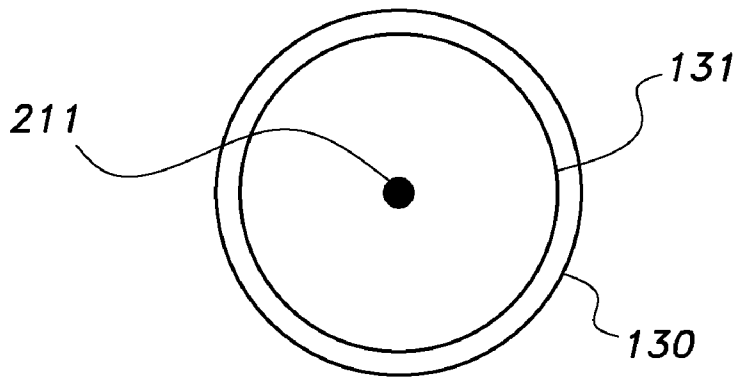
**FIG. 6A**



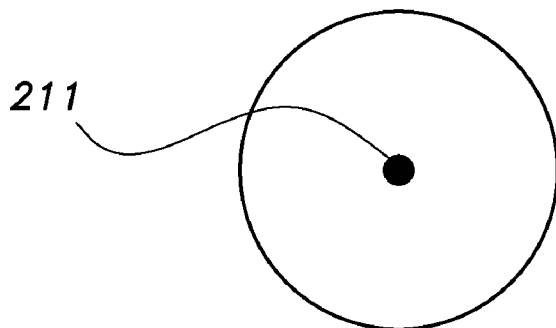
**FIG. 6B**



**FIG. 7A**

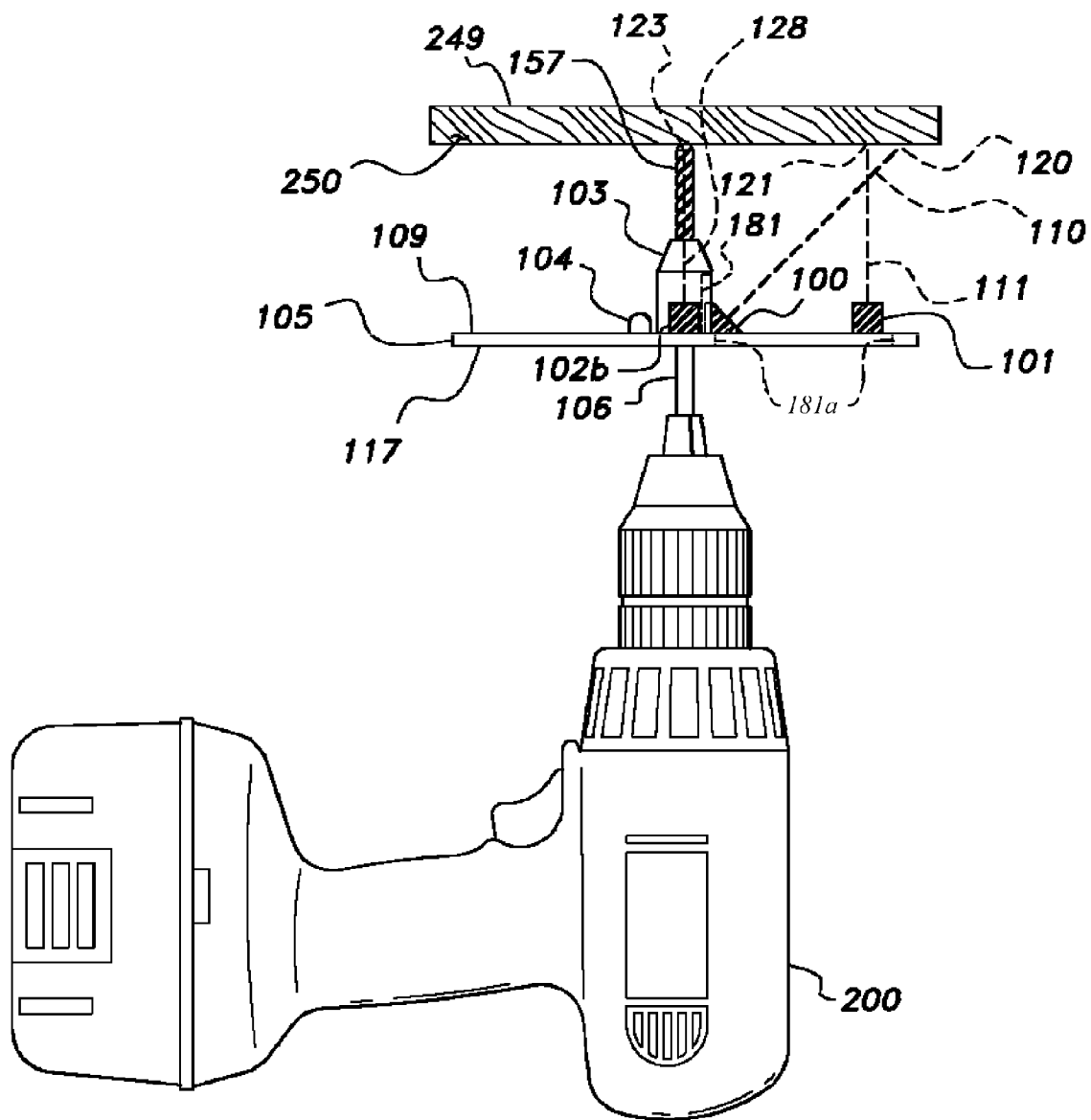


**FIG. 7B**

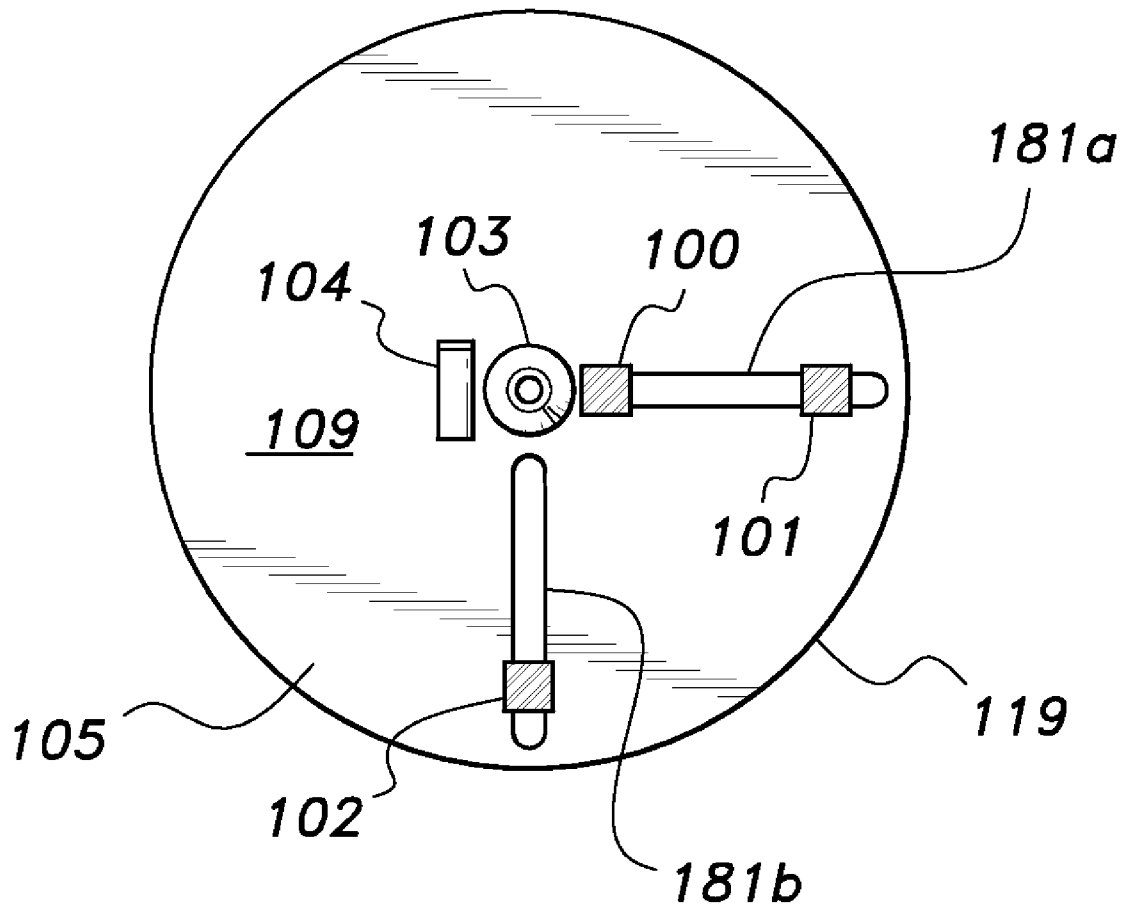


**FIG. 7C**

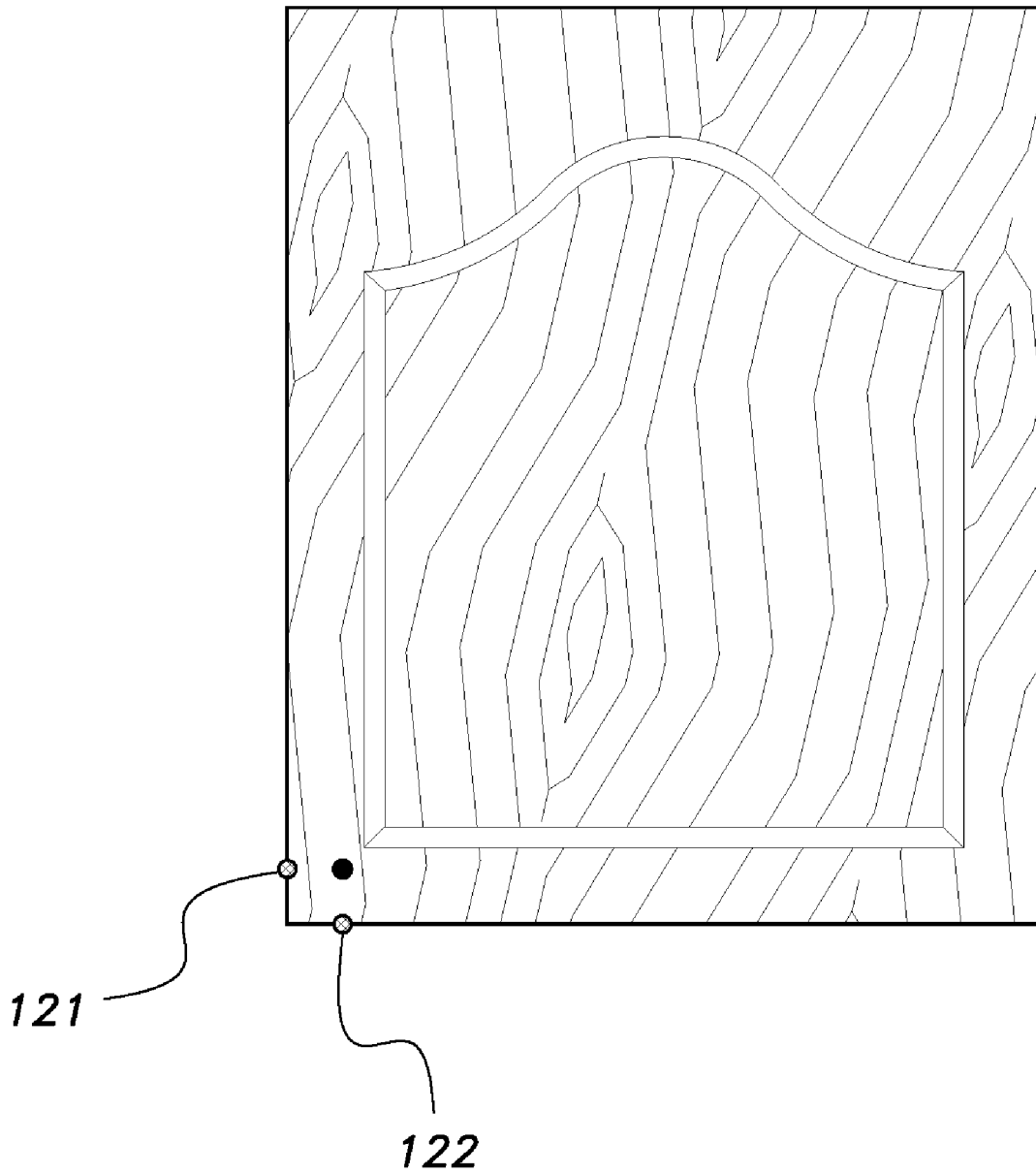




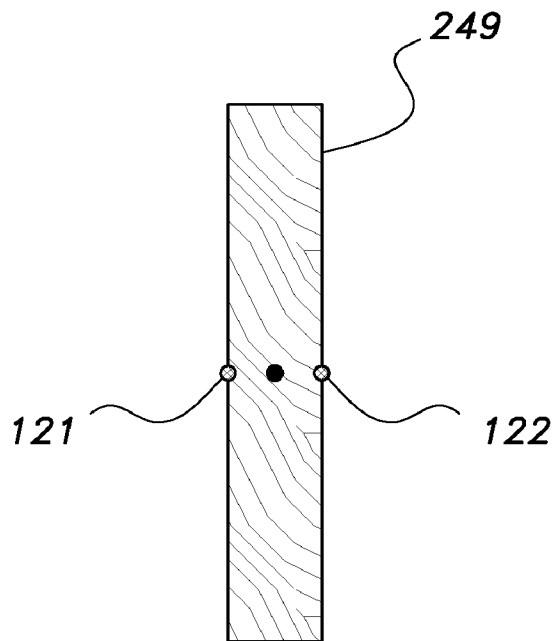
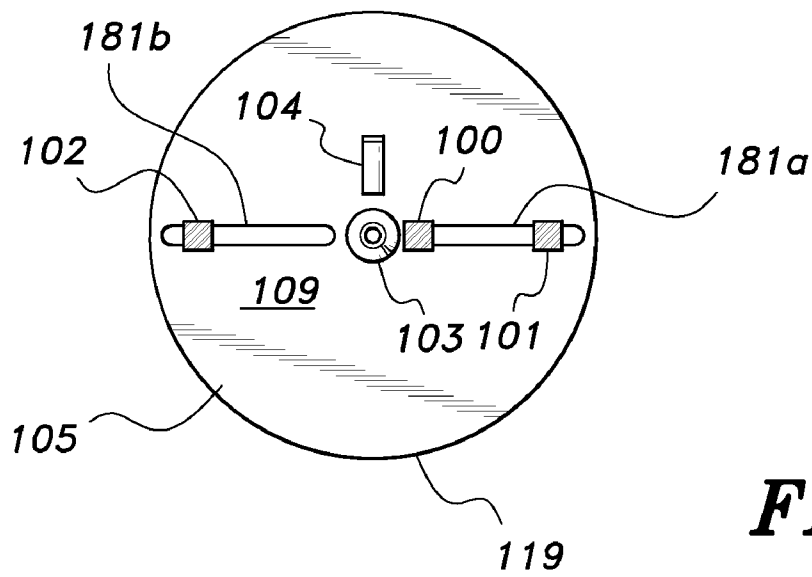
**FIG. 9A**



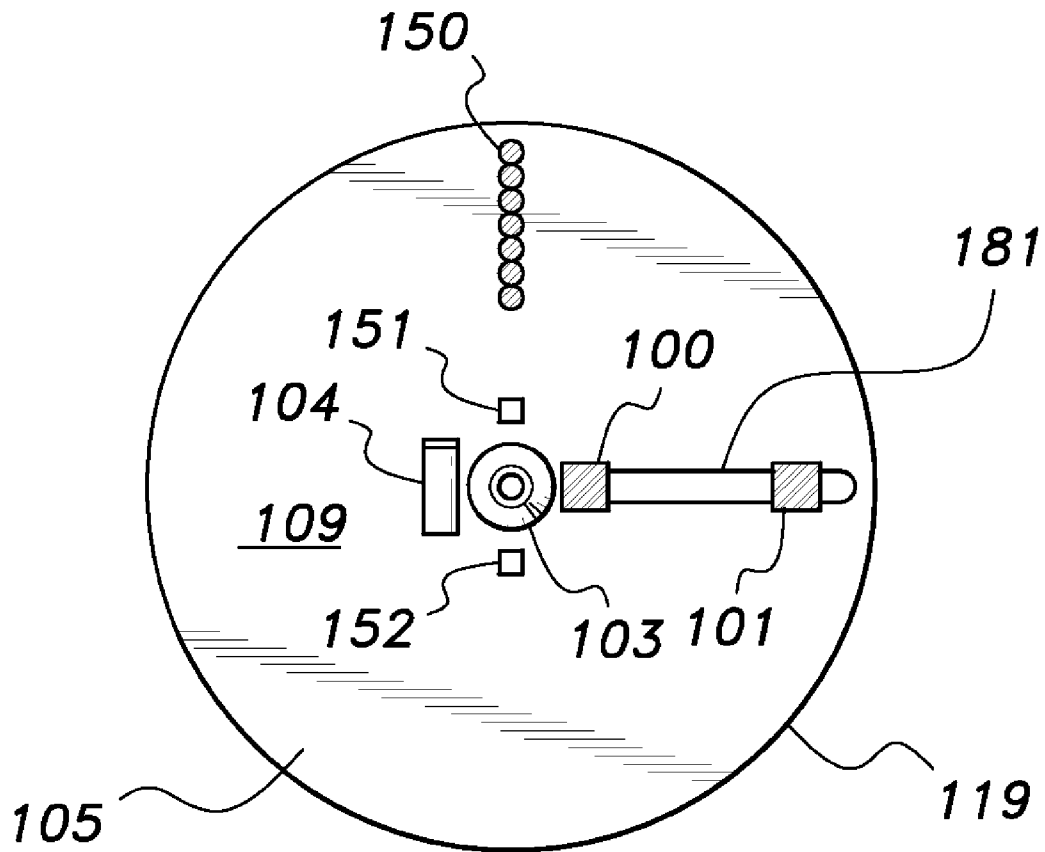
**FIG. 9B**



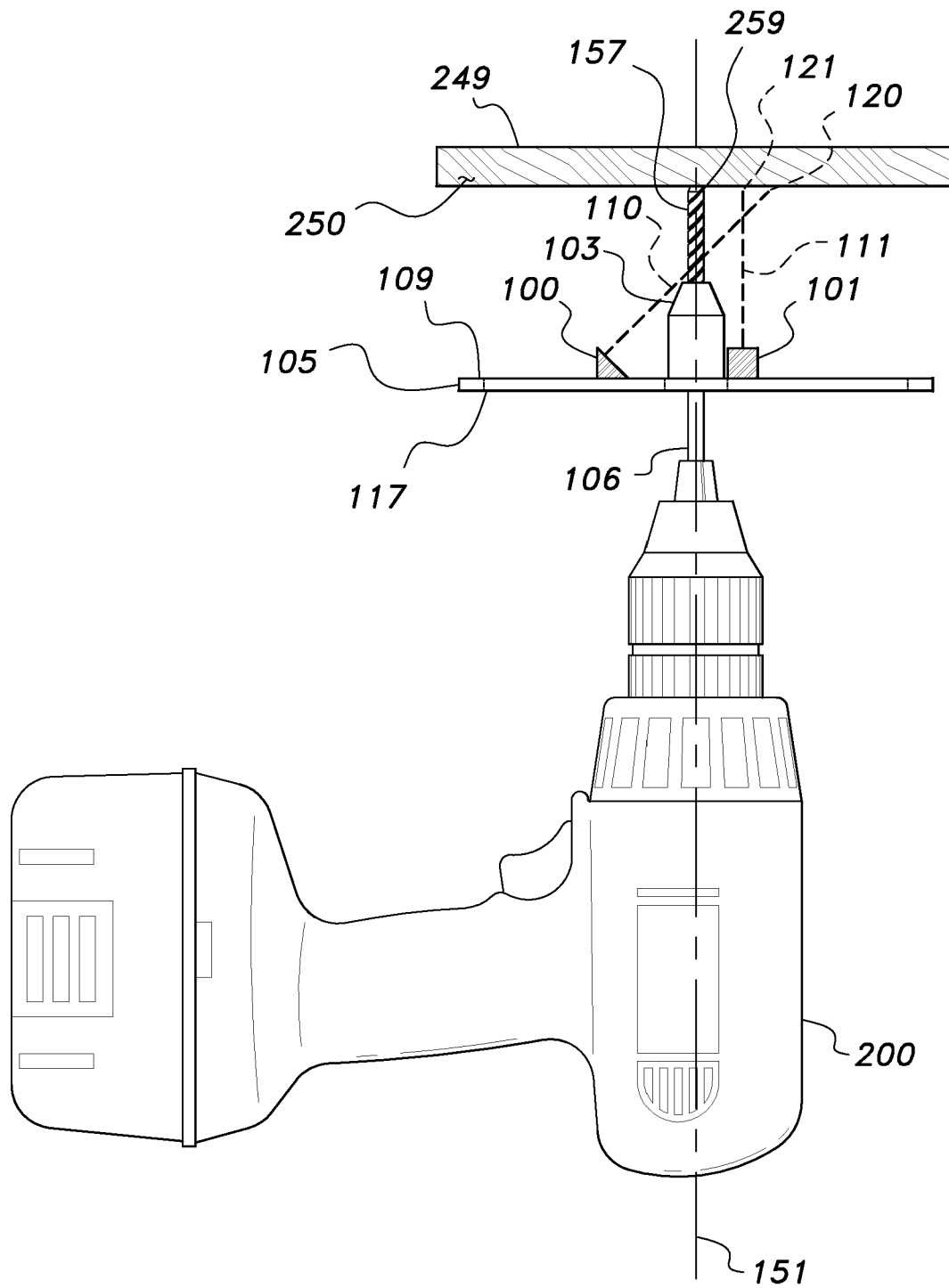
**FIG. 10**



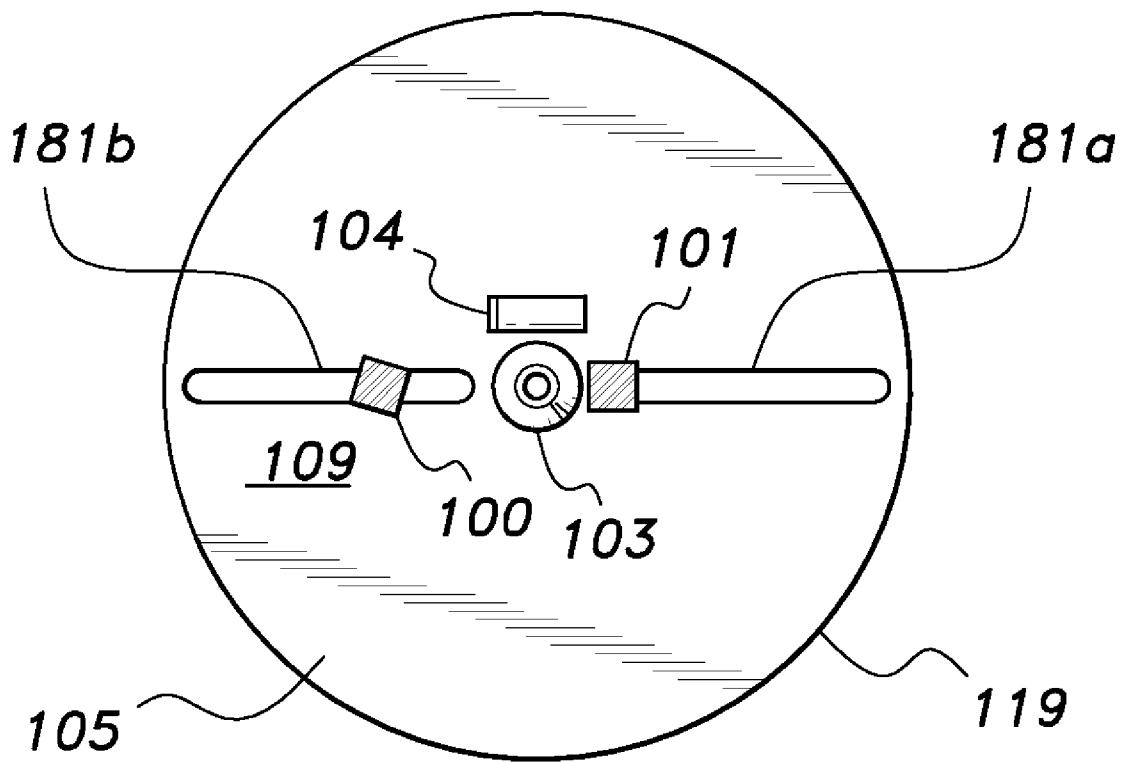




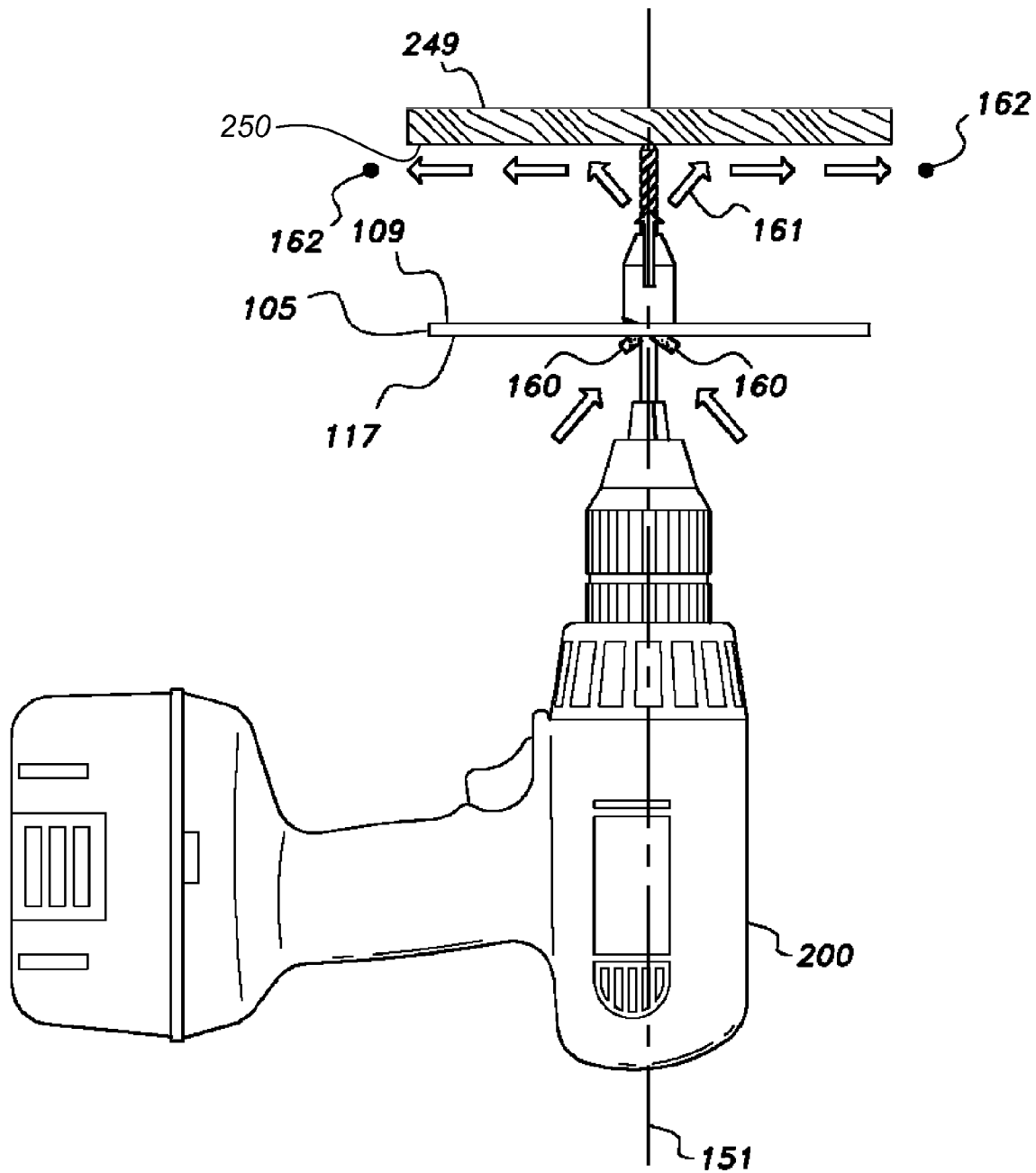
**FIG. 13**



**FIG. 14A**

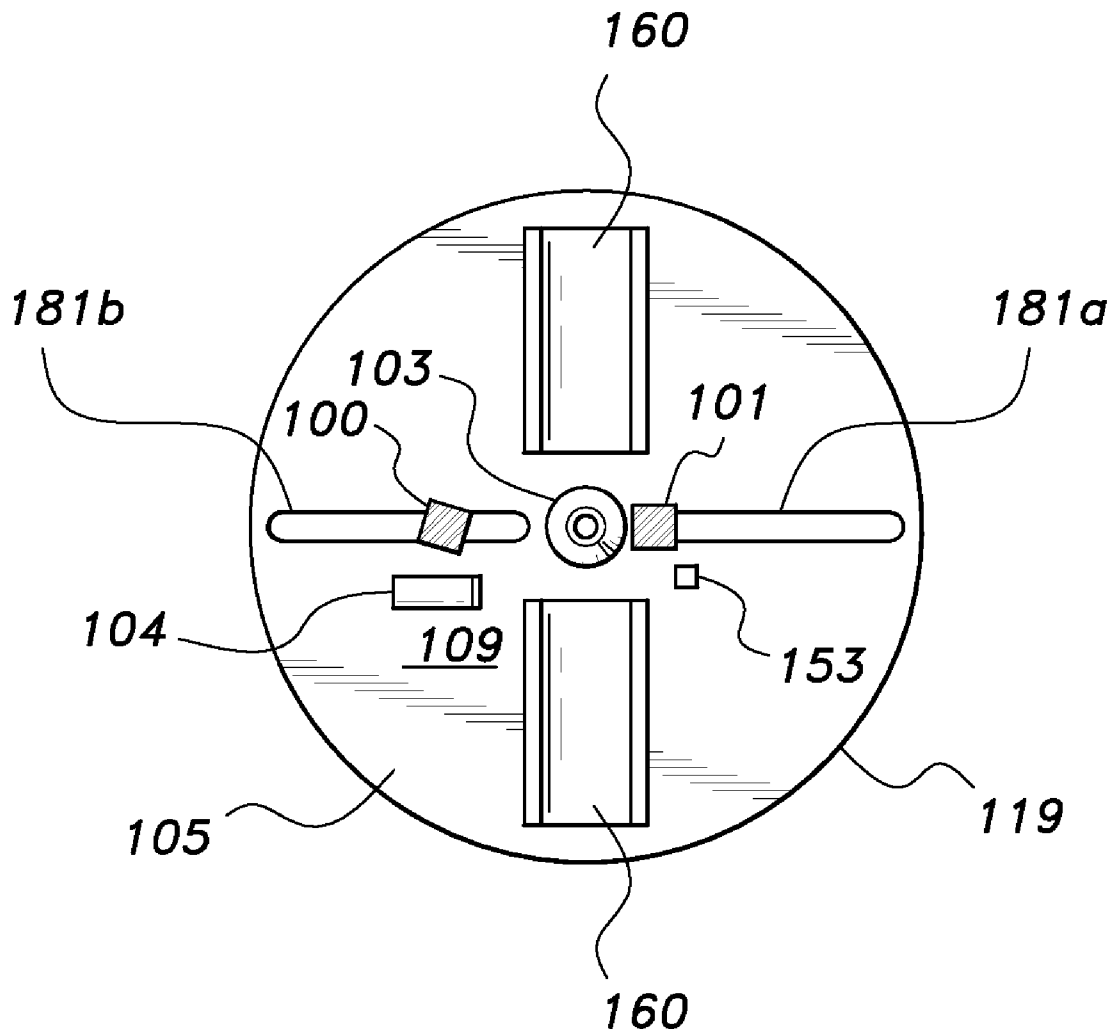


**FIG. 14B**

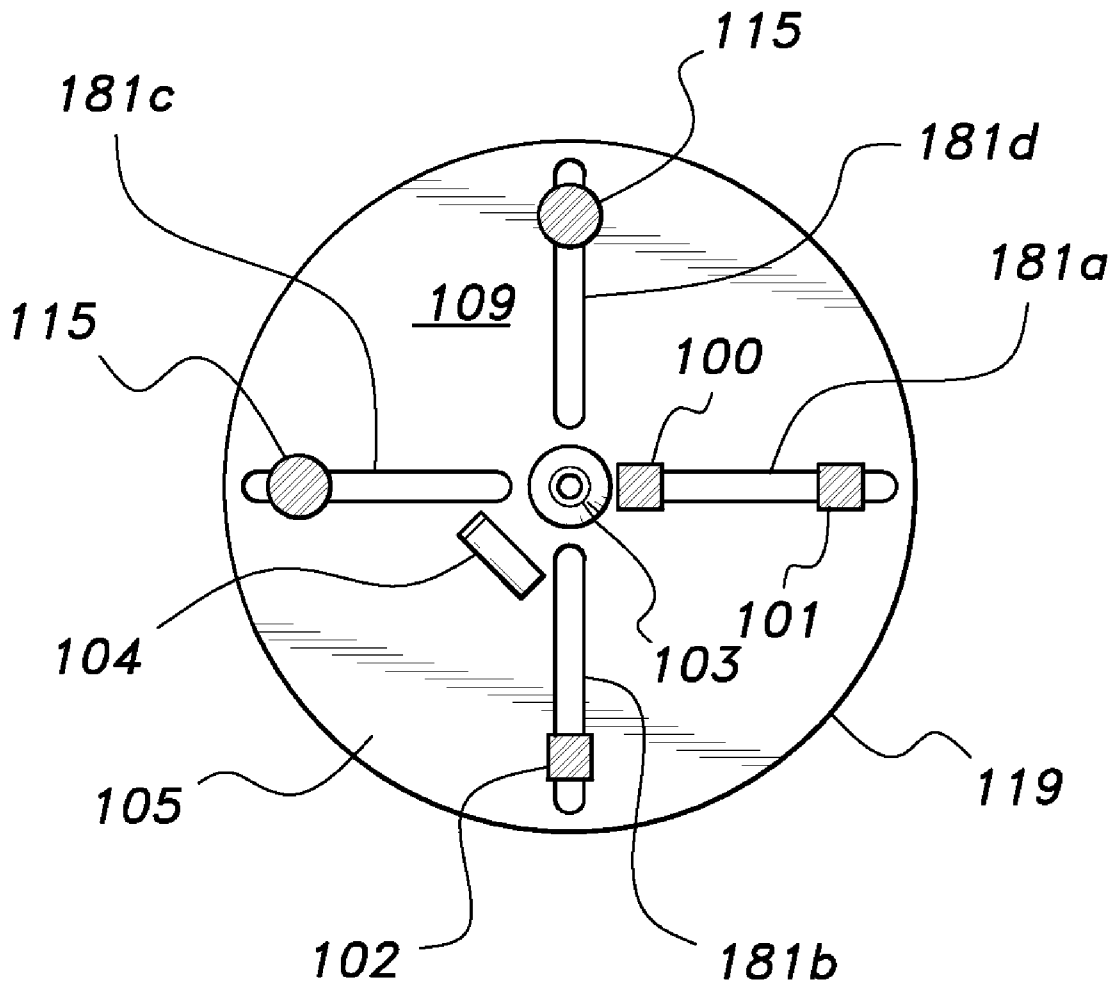


**FIG. 15**

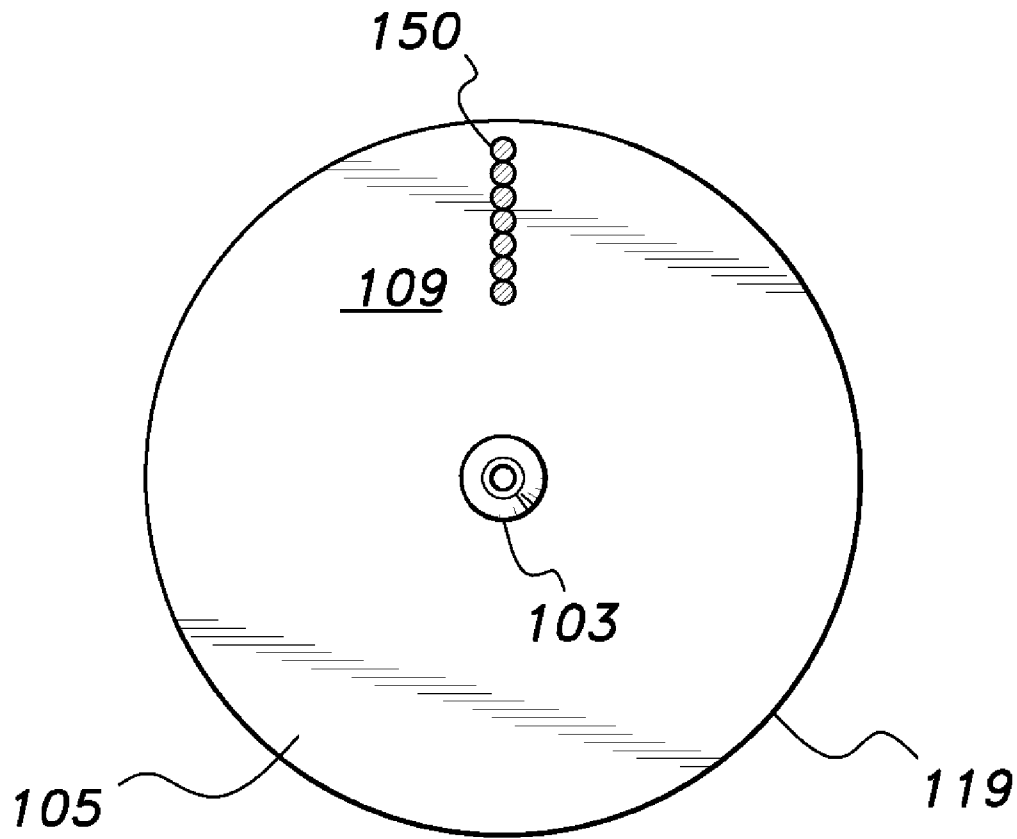




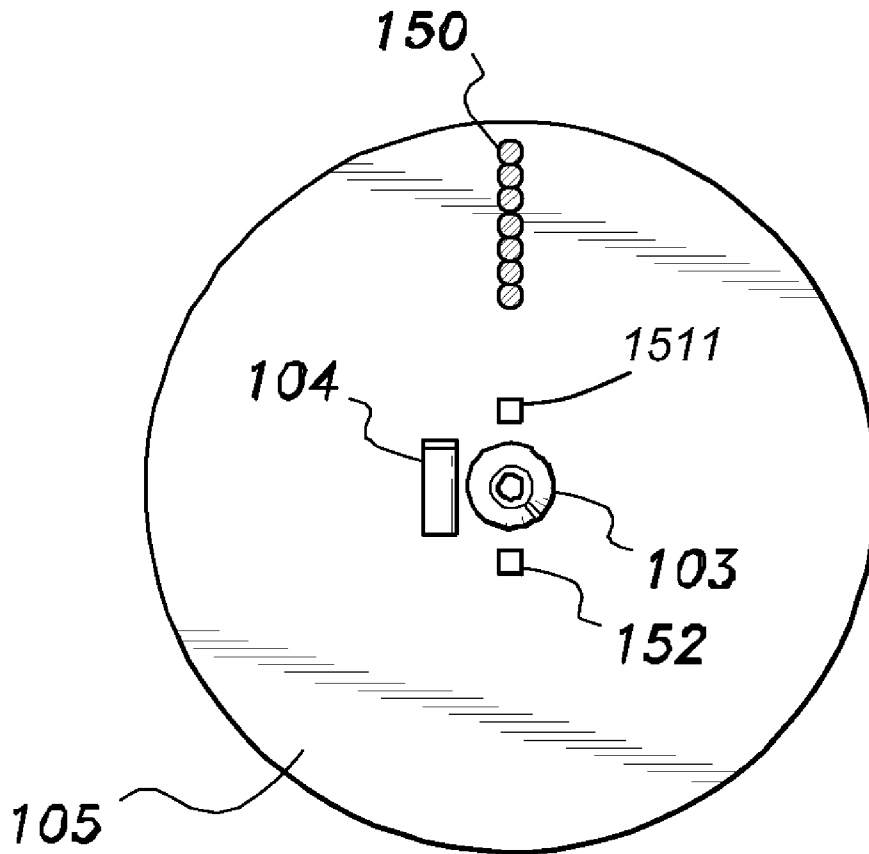
**FIG. 16B**



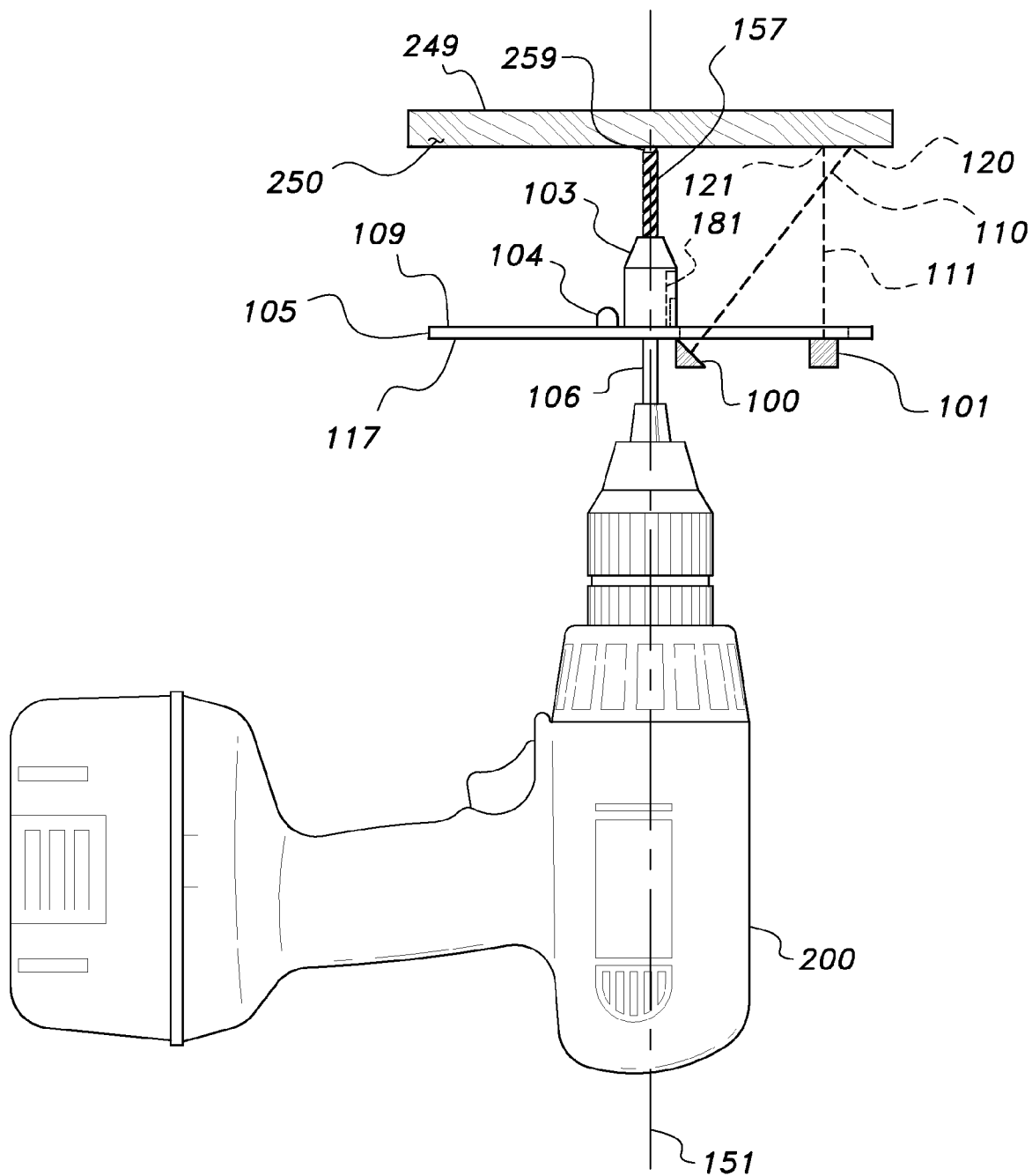
**FIG. 17**



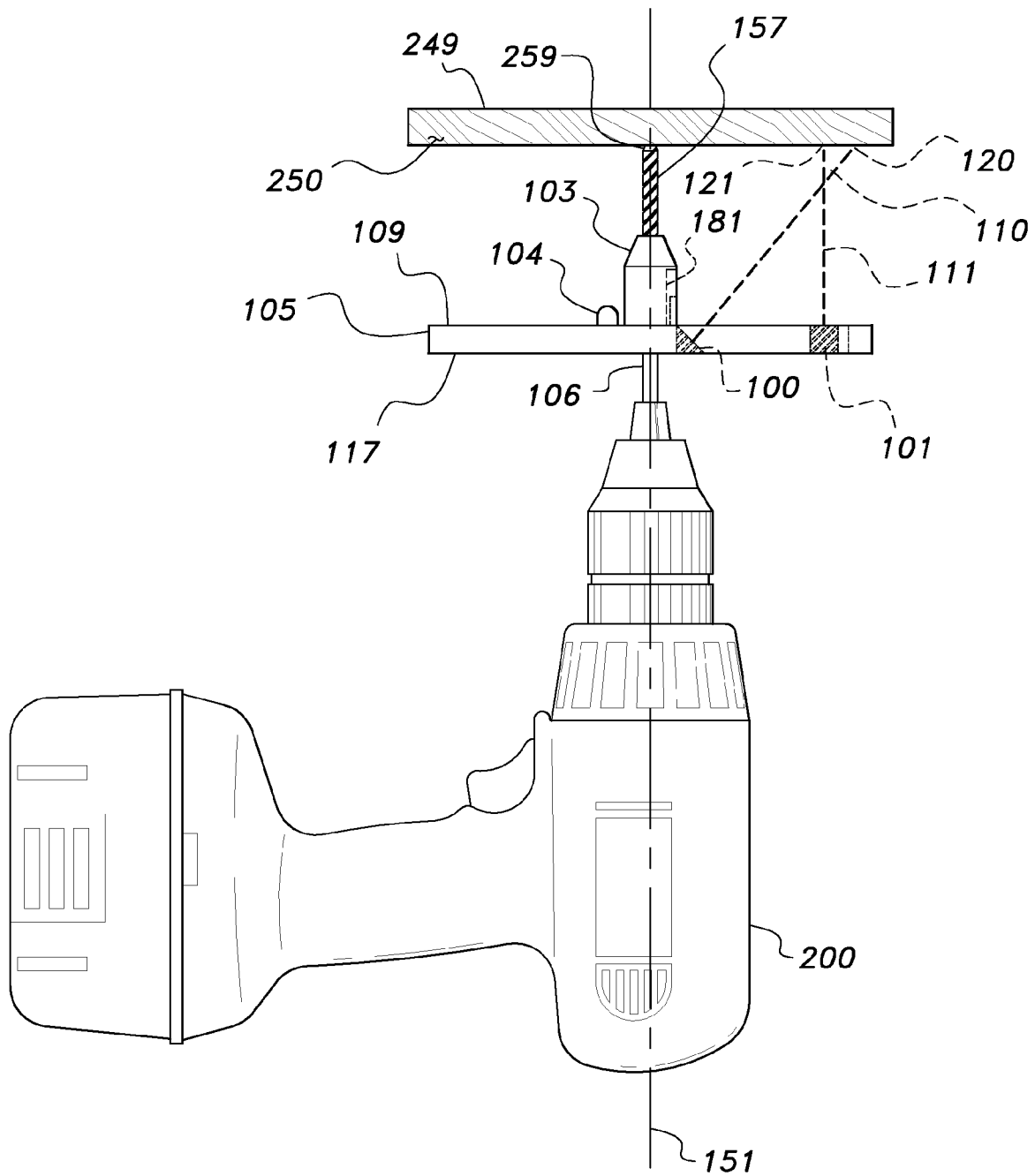
**FIG. 18**



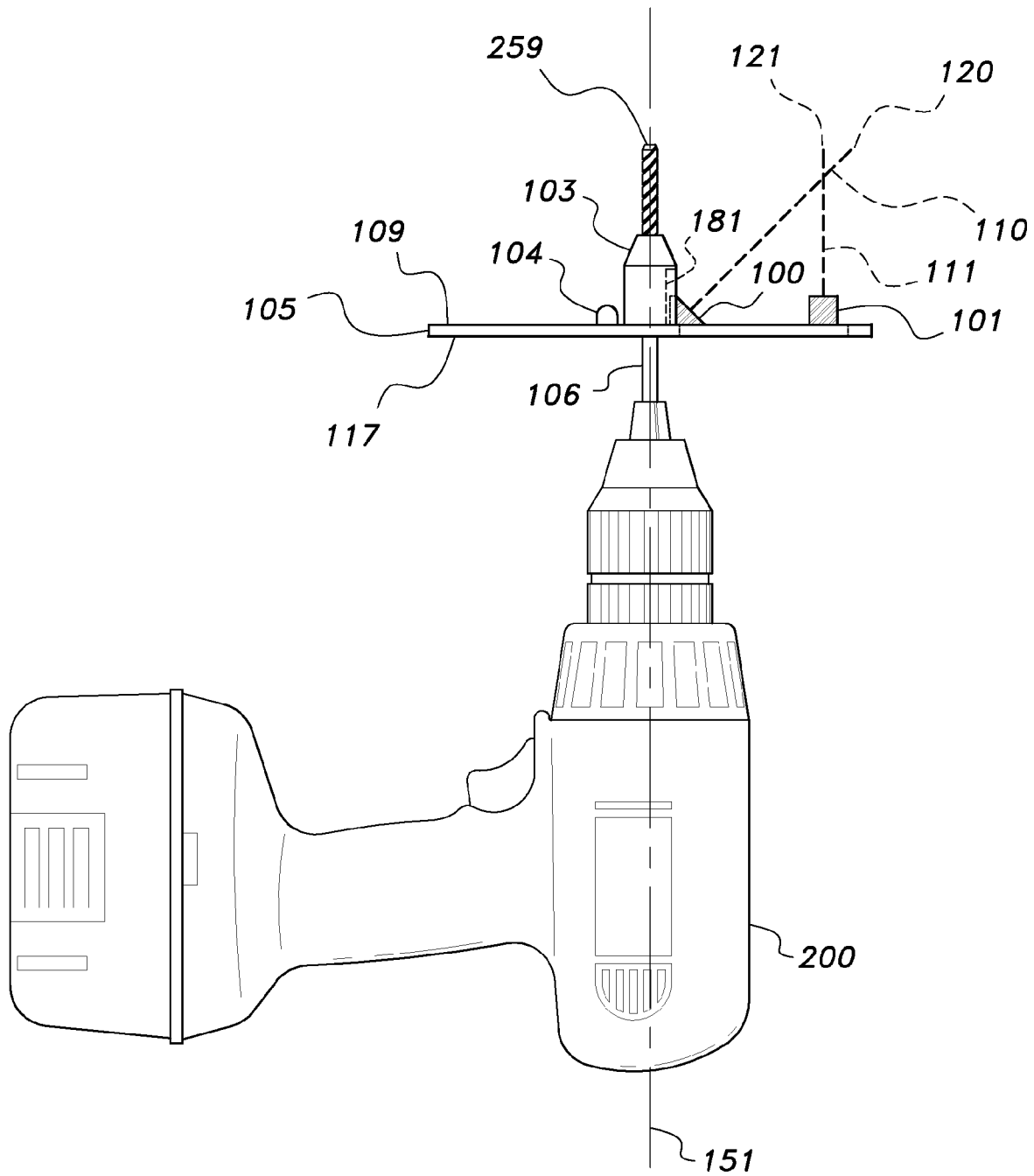
**FIG. 19**



**FIG. 20**



**FIG. 21**



**FIG. 22**

US 7,992,311 B2

1

## ROTARY BORING TOOL ALIGNMENT AND DEPTH INDICATION SYSTEM

### CROSS-REFERENCE TO RELATED APPLICATIONS

This application claims the benefit of priority from U.S. Provisional Patent Application Ser. No. 61/045,611 (filed Apr. 17, 2008) and 61/050,239 (filed May 4, 2008). The contents of Provisional Patent Application Ser. Nos. 61/045, 611 and 61/050,239 are incorporated in their entirety herein by reference.

### STATEMENT REGARDING FEDERALLY SPONSORED RESEARCH OR DEVELOPMENT

Not Applicable.

### FIELD OF THE INVENTION

This invention is directed to rotary boring tool alignment and depth indication systems.

### BACKGROUND OF THE INVENTION

DIY and even skilled craftsmen and women often experience difficulty in maintaining correct alignment of a rotary boring tool with a work surface such as a work-piece being drilled by a hand-held power drill. Furthermore, DIY and even skilled craftsmen and women often experience difficulty in determining the depth of a rotary boring instrument as it penetrates a work surface such as a work-piece being drilled by the bit of a hand-held power drill.

There is a continuing need for an apparatus that helps a user to maintain correct alignment of a rotary boring tool with a work surface as well as to indicate the depth of the boring instrument or cutting tool.

### BRIEF DESCRIPTION OF THE DRAWINGS

FIGS. 1A and 1B show a first embodiment of the invention. FIGS. 2A through 2C show visible projections on the surface of a work piece according to one aspect of the invention.

FIGS. 3A and 3B respectively show the result of correct and incorrect alignment with respect to a work surface according to one embodiment of the present invention.

FIGS. 4A through 4D show the result of correct and incorrect alignment with respect to a work surface according to another embodiment of the present invention.

FIGS. 5A and 5B show how a first light source can be adjusted in the vertical plane with respect to a cutting tool holder in the form of a chuck.

FIGS. 6A and 6B show markings on a body (105) according to one aspect of the invention.

FIGS. 7A through 7C show various circular light projections projected on a work piece surface according to the invention.

FIG. 8 shows a split beam of light according to the invention.

FIGS. 9A and 9B show an additional light source according to the invention.

FIG. 10 demonstrates drill tip positioning on a work piece according to the invention.

FIGS. 11A and 11B demonstrates drill tip positioning on a work piece according to the invention.

FIG. 12 showing light sources tilted at an angle according to the present invention.

2

FIG. 13 shows a persistence of vision setup according to the invention.

FIGS. 14A and 14B demonstrate the use of first and second light sources located on opposite sides of a cutting tool holder according to the invention.

FIGS. 15 through 16B show an aspect of the invention designed to remove debris.

FIG. 17 shows an aspect of the invention involving the deployment of counter-weights.

FIGS. 18 and 19 show an example of a Persistence of Vision (POV) aspect of the invention.

FIG. 20 shows light sources located below a body member (105).

FIG. 21 shows light sources integrated into a body member (105).

FIG. 22 shows a power drill modified according to an aspect of the invention.

### SUMMARY OF THE INVENTION

A system for a rotary boring tool that enables a user of the tool to align the tool perpendicularly with respect to a work surface of a work piece. In one embodiment the system enables a user to gauge distance or depth drilled into the work piece.

### DETAILED DESCRIPTION OF THE INVENTION

This invention is directed to rotary boring tool alignment and depth indication systems.

In one embodiment of the invention a rotary power tool alignment and depth indication system is provided to improve both the functionality and usability of rotary power tools. The system may be used on any type of rotating power tool. This includes, but is not limited to hand held-power drills of all sorts, stationary drill presses, smaller Dremel® drill tools, as well as larger boring devices. Furthermore, the system can be used on other types of rotating machinery such as milling machines and lathes.

It will be understood that such terms as “upper and lower”, “front and rear”, and “top and bottom” are used for convenience to describe relative directional reference in the common orientation of system as shown in FIG. 1A.

For purposes of simplicity, the system embodiments described below are provided in the context of hand-held power drills. It should be noted, however, that the advantages provided by the system are equally applicable to all types of rotary power tools. These advantages include, but are not limited to, visual work surface alignment, visual drill bit or cutting tool depth indication, and visual drill bit or cutting tool work surface positioning.

In one embodiment (see FIGS. 1A and 1B), the system comprises of first and second light sources 100 and 101, a cutting tool holder such as, but not limited to, a chuck 103, and a power source 104. In this embodiment the first and second light sources 100 and 101, and power source 104 are mounted on a body 105 such as a circular disk, with the first and second light sources 100 and 101 essentially inline with the center position of the chuck 103. The body 105 is shown in FIG. 1A connected (either permanently or temporarily) to the power drill 200 so that the rotational output of the drill is translated to the body 105, which then rotates as well. When a drill bit is attached to the system chuck 103, the drill and the system can be used in unison to provide improved drilling and boring operations. The power drill 200 defines a longitudinal axis 151 that passes through the rotary parts of the power drill 200 which in FIG. 1A includes chuck 103 a shaft 106, and a

US 7,992,311 B2

3

drill bit **157** extending from chuck **103**. In FIG. 1A the body **105** is mounted in a transverse plane (i.e., at a 90° angle) with respect to the longitudinal axis **151**. The body **105** defines a top surface **109**, a bottom surface **117**, and a circumference **119**. It should be understood that the chuck **103** can be any suitable cutting-tool holder such as a connector able to secure the drill bit **157** to the rotary tool such as a power drill **200**.  
Visual Work Surface Alignment

With regards to proper work surface alignment, the system allows a power drill user to quickly visualize if the drill is aligned (both vertically and horizontally) with a work surface **250** of a work piece **249**. This is important because proper horizontal and vertical alignment will provide for a bore-hole that is completely perpendicular to the work surface. Furthermore, the system is advantageous because it does not rely on gravity, so the orientation of the work surface is inconsequential.

In the embodiment pictured in FIGS. 1A and 1B, the system produces two essentially circular visible projections on a work surface **250** that provide a visual indication of drill alignment or misdirection. More specifically, first and second light sources **100** and **101** respectively project inner and outer concentric circles of light **130** and **131** (see FIGS. 2A through 2C) on the work surface **250** when the power drill **200** is being held at a perpendicular angle with respect to the work surface **250**. These laser projections are created by the rotation of the embodiment in conjunction with the rotating portion of the power drill **200**.

In one embodiment of the invention as depicted in FIGS. 2A through 2C, a power drill **200** aligned perpendicular with respect to a work surface **250** produces two visible and essentially concentric circular projections (in FIG. 2A shown as first and second concentric circles **130** and **131**) on a work surface **250** with the position of the tip **259** of a drill bit **157** located at the center **211** of the concentric circular projections. More specifically, first and second light sources **100** and **101** respectively produce first and second light beams **110** and **111**, which in turn respectively project first and second visible projections **120** and **121** on the work surface **250**, which upon rotation of the system in turn respectively generate first and second concentric circle projections **130** and **131** onto the work surface **250** when the power drill **200** is aligned perpendicularly with respect to the work surface **250**. Conversely, a rotary boring tool such as, but not limited to, a power drill **200** that is misaligned with regards to the work surface **250** (also pictured in FIGS. 2B and 2C) produces first and second non-concentric (non-centered) circles **140** and **141**. These non-concentric circles may also contain some elliptical distortion. The combination of these factors makes it easy for a power drill user (i.e., power drill operator) to visualize and quickly correct for any drill misalignment.

In this embodiment, first light source **100**, which may be a laser, LED, or other light source, produces a first light beam **110** that is at an acute angle of, for example, 45 degrees to the drill bit **157**. When the embodiment is not rotating, the first light beam **110** from first light source **100** produces a first visible projection **120** on the work surface **250**. Second light source **101** (which may also be a laser, LED or other light source) produces a second light beam **111** that is parallel to the longitudinal axis **151** and hence parallel to the illustrated drill bit **157**. When the embodiment is not rotating, the second light beam **111** from second light source **101** produces a second visible projection **121** on the work surface **250**.

The first and second visible projections **120** and **121** are typically, but not necessarily, dot-shaped. For example, the first and second light sources **100** and **101** can optionally include, or are operatively coupled to, one or more lenses that

4

manipulate the light output from the light sources to provide visible projections that are not regular dot-shaped. Such manipulations can include, but are not limited to projection shaping or focusing. The first and second light sources **100** and **101** could, for example, be laser light sources that incorporate one or more diffractive optical elements (DOEs). DOEs are described, for example, in U.S. Pat. Nos. 5,151,917, 4,846,552 and 4,895,790. U.S. Pat. Nos. 5,151,917, 4,846,552 and 4,895,790 are incorporated herein by reference in their entirety.

In this embodiment when the power drill **200** is aligned correctly against a work surface **250**, the work surface **250** becomes the third leg of a right angle triangle. As depicted in FIG. 3A the first and second light beams **110** and **111** combine with the work surface **250** to create a 45°-45°-90° right angle triangle, with first light beam **110** producing the hypotenuse, second light beam **111** producing the c1 leg, and the work surface **250** the c2 leg. In this non-limiting example, the c1 leg is equal in length to the c2 leg, and the first and second dot-shaped visible projections **120** and **121** form the end points of leg c2.

When this embodiment is aligned perpendicularly against a work surface **250** and rotating with the output of the power drill **200**, the distance between the first and second dot-shaped projections **120** and **121** (the c2 leg), is constant. In correct alignment the first and second light beams **110** and **111** producing first and second dot-shaped projections **120** and **121** respectively produce first and second concentric circle projections **130** and **131** on the work surface **250**. Conversely, when the embodiment is misaligned against a work surface **250** and rotating, the distance between first and second dot-shaped projections **120** and **121** (the c2 leg) is different (see FIG. 3B). Since the embodiment is no longer producing a right angle triangle, this produces the effect of two essentially non-aligned, first and second non-concentric (non-centered) circles **140** and **141**.

In another embodiment, the position of one or more of the light sources can be altered with reference to their linear distance from each other and the longitudinal axis **151**. This has the effect of changing the distance between the first and second visible projections **120** and **121** (the c2 leg length) on the work surface **250**, and thus the diameter of the first and second concentric circles **130** and **131**. Such an adjustment is optimal for drill bits of different lengths and/or for the configuration of different visual alignment effects. FIGS. 4A through 4D presents the latter—an example of a different type of visual alignment with regards to a work surface **250**. In this example, first light source **100** is positioned so that its first circular projection **130** is equal in diameter to that of the second circular projection **131** from light source **101** when the drill bit **157** is aligned perpendicularly with the work surface **250**.

As depicted in FIG. 4A, perfect alignment is indicated by the overlapping of the two projections **130** and **131**. Conversely, any misalignment is indicated by a deviation in shape or position of the first and second non-concentric circles **140** and **141**. This embodiment and others may also include the optional use of different colored lights so as to differentiate between the two projections. An example would be a red light **100** and a green light **101**.

Referring specifically to FIGS. 4A and 4D, to ensure that the first beam **110** produces first circle **130** that coincides on the work surface **250** with second circle **131** produced by the second beam **111** the angle of the first beam of light **110** from first light source **100** can be adjustable such that the first beam

US 7,992,311 B2

5

110 produces a circle of light on the work surface 250 that coincides with the circle of light provided by the second light source 101 (see FIG. 4D).

In one aspect of the invention the first light source 100 can be moved up or down the cutting tool holder, such as chuck 103, by means of, for example, a slot or channel 181 mounted vertically on a chuck 103 (shown, e.g., in FIG. 5A). In this embodiment the first light beam 110 produced by first light source 100 is preferably projected at an acute angle away from the longitudinal axis 151. Channels or slots 181 can also be located on the body 105 such as the top surface 109 of body 105, e.g., see FIG. 11A.

The body 105 can be made of transparent plastic or is substantially transparent to the extent that the body 105 allows passage of light beams sufficient for a human eye to detect visible projections such as 120 and 121. For example, body 105 can be transparent to first and second light beams 110 and 111 thereby allowing the corresponding light sources to be located on the bottom surface 117 of body 105. FIG. 20 illustrates a body 105 sufficiently transparent to allow passage of first and second light beams 110 and 111 through the body member such that first and second light sources 100 and 101 are located on the bottom surface 117 of body 105. The light sources can, if preferred, be at least partly located inside the body 105 or located inside the body 105 as shown, for example in FIG. 21 to give a flush or substantially flush fit with respect to body 105.

Selectively changing or adjusting the positions of one or more of the light sources has the effect of changing the distance between the first and second visible projections 120 and 121 (the  $c_2$  leg length), and thus the diameter of the circles when the system is rotating with the drill. For example, first light source 100 can be adjusted along the longitudinal axis 151 with respect to chuck 103 or body 105 (see FIGS. 5A and 5B). A slot, groove or track can be attached or integrated into the cutting tool. For example, FIGS. 1A and 5A show a slot 181 in vertical orientation and integrated into chuck 103. By moving or positioning the first light source 100 at different points along slot 181 with respect to chuck 103 this has the effect of changing the position of first visible projection 120 on a work surface 250, and thus the diameter of the first circular projection 130 that is produced when the system is rotating with the drill.

In another embodiment (FIGS. 6A and 6B), the body 105 may have markings and/or indicators that provide the user with guidance on how to position the adjustable lights for different types of operations and drill bit lengths. The markings could include, but are not limited to incremental points in a linear pattern 170 (similar to a ruler), or even drill bit images 171 that provide a user with an easy system setup or guidance mechanism. For example, the markings could inform a user where to position the light sources to obtain overlapping circles, as depicted in FIG. 4A, with respect to a drill bit of a selected length.

In another embodiment (FIGS. 14A and 14B), first and second light sources 100 and 101 are positioned (either fixed or adjustably) on opposite sides of a cutting tool holder—shown as chuck 103. This allows for the use of longer drill bits, and/or for a body 105 that can be reduced in size, e.g., reduction in the diameter of the body 105. Furthermore, since the light sources are more evenly distributed on the body 105, this embodiment provides for more stability while rotating. The first and second light sources 100 and 101 can be moved along slots 181 (generally denoted by “181”, but if more than one slot then represented by derivatives of “181”, e.g., labels “181a” and “181b”). It should be understood that the slots can take any suitable form such as, but not limited to: tracks,

6

grooves or channels; also, the light sources can be located inside the body 105 as shown in FIG. 21 thereby rendering the light sources flush or substantially flush with respect to the top 109 and/or bottom surface 117 of the body 105.

The embodiment pictured in FIGS. 14A and 14B has a first light source 100 that produces a first light beam 110 that is at a 45 degree angle (or close to a 45 degree angle) to the drill bit 157 and longitudinal axis 151, and a second light source 101 that produces a second light beam 111 that is essentially parallel to the drill bit and longitudinal axis 151. In this embodiment the light source 100 or first light beam 110 can be modified so that the first visible projection 120 is visible on the work surface 250 (and not the drill bit 157). For example, the first light source 100 could be rotated in the transverse plane with respect to the longitudinal axis 151 by an amount just sufficient so that the first light beam 110 misses or substantially misses or at least partly avoids the drill bit 157 and be projected onto the work surface 250. FIG. 14B depicts this with a light source 100 that is slightly rotated. Further, the first light source 100 could be manipulated so as to produce a beam that is visible on both sides of the drill bit 157, e.g., via a beam splitter splitting the single beam output of the first light source 100 to pass either side of the drill bit 157. It is preferred that during normal operation of the system that the first and second light beams 110 and 111 combine with a work surface 250 to create a 45°-45°-90° right angle triangle.

Although the preferred embodiment includes a first light source 100 that produces a first light beam 110 that is essentially at an acute angle of 45 degree angle to the drill bit 157 (and longitudinal axis 151), other embodiments may include a light source that is either fixed or adjustable to some acute angle other than 45 degrees. Likewise, although the preferred embodiment includes a second light source 101 that produces a second light beam 111 that is essentially parallel to the drill bit 157 (and longitudinal axis 151), other embodiments may include a light source that is either fixed or adjustable to some angle other than parallel to the drill bit 157 (and longitudinal axis 151).

#### Visual Drill Bit or Cutting Tool Depth Indication

With regards to drill bit or cutting tool depth indication, the system (i.e., the present invention) optionally provides a power drill user with the ability to quickly visualize the depth of a drill bit as it bores into a work surface. This is important because the power drill user may need to limit or monitor the depth of their drilling operations. This feature may be used in combination with other features, such as work surface alignment.

In one embodiment this is accomplished by watching the outer circular laser projection (labeled as “130” in FIGS. 7A and 7B) collapses on the inner circular projection 131 as the drill is pressed forward into the work surface 250. FIGS. 7A through 7C demonstrate what a power drill user will see as the drill 200 is pressed forward into a work surface 250 of a work piece 249. In this embodiment, the outer circular projection 130 collapses on the inner circle 131 and produces a single circle; this indicates that the drill bit has moved forward by the spatial difference between the radius of the first and second circles in the starting position. It should be understood that the work surface 250 of work piece 249 is not limited to a specific work piece.

As depicted in the first embodiment (FIGS. 1A and 1B), an optional feature allows the drill bit depth measurement to be set ahead of time by adjusting the distance between the first and second visible projections 120 and 121 on the work surface 250. Since various embodiments allow the position of first and second light sources lights 100 and 101 to be adjusted, this has the effect of changing the diameter of the

first and second circular projections **130** and **131** that are produced when the system is rotating with the drill. Therefore, the starting position of circular laser projection **130** on the work surface may be inside, outside, or equal to that of circular laser projection **131**. This provides the power drill user with maximum flexibility.

In another embodiment, second light source **101** may be split by a beam splitter **107** into two or more beams **111** and **112** thus producing visible projections on the work surface **250** in addition to first and second visible projections **120** and **121**. An example is depicted in FIG. **8** which shows first, second and third visual projections **120**, **121** and **122**. In this particular example, the split projections may be further spaced at equal intervals such as a centimeter or inch. When the system is rotating with the rotating parts of the power drill **200**, the split beam results in multiple circular projections on the work surface. Such projections provide for the ability to incrementally monitor the progress of a drill bit **157** as it bores into a work surface **250**. This effect may also be accomplished through the use of additional light sources like **101** mounted at equal spaced distances in a linear pattern.

#### Visual Drill Bit or Cutting Tool Work Surface Positioning

The system may also provide methods for a power drill user (i.e. operator) to utilize one or more of the light projections as markers on the work surface **250** to position the drill bit **157** (and thus the location of the bore hole) with regards to elements on the work surface **250** or adjacent surfaces. This positioning ability makes drill bit placement operations more precise, and prevents the need for “pre-marking” the work surface prior to drilling.

For example, if a power drill user is drilling knob holes in a series of identical cabinet doors, the position of the drill bit **157** and more particularly the tip **259** of the drill bit **157** (and thus the location of the associated bore hole) should be identical and consistent on all cabinets. Normally the user would be forced to measure each cabinet, and mark the target bore-hole position prior to drilling operations.

In one embodiment, one or more additional light sources are added to the system for drill bit positioning on a work surface **250**. As depicted in FIGS. **9A** and **9B**, an optional additional light source **102** is added to the 6 o'clock position on the system body **105** for cabinet (or corner) drilling operations. The additional light source **102b** produces third light beam **128**, which produces visible projection **123** on the work surface **250**. In this configuration, the first and second visible projections **120** and **121**, which can be dot-shaped projections, from first and second light sources **101** and **102** can be used to position the drill bit **157** on the work surface with reference, for example to the corner ends of a cabinet. An example of the effect on a cabinet door is pictured in FIG. **10**. It should be noted that drill bit work surface positioning is done by manually rotating the system body **105** into the correct orientation with regards to the work surface elements prior to drilling operations. It is also possible in this and other embodiments to turn off first light source **100** if it is not used prior to drilling operations.

In another embodiment, an optional third light source **102** is added to the mounting body **105** such that the optional third light source **102** is located on the opposite side of chuck or cutting tool holder **103** from second light source **101**, wherein second and third light sources **101** and **102** are equidistant from the circumference **119** of the mounting body **105** for centering operations. Such centering operations can be used to quickly find the center of common work surfaces such as wooden studs, deck panels, downspouts, bricks, etc. An example of the system and its effect on a wooden stud is depicted in FIGS. **11A** and **11B**. In other embodiments, the

system may also include additional light sources in the some combination of the 3, 6, 9, and 12 o'clock positions.

In another embodiment, one or more of the light sources have the capability to tilt along their X or Y axis's. This provides further capability for alignment with work surface (or adjacent surface) elements. As depicted in FIG. **12**, second light source **101** is tilted along its X axis. In this embodiment, it could also tilt along its Y axis, or some combination of X and Y.

#### Light: Sources, Manipulation, and Positioning

The system and its various embodiments can use a variety of light sources, light source manipulation, and light source positioning. These may be implemented alone or in various combinations.

In the one embodiment, the light sources or sources are laser light sources. In another embodiment, the light sources are LEDs (Light Emitting Diodes), or some other preferably low-power illumination source. Different types of light sources may also be combined in a single embodiment. The light sources could, for example, be laser light sources that incorporate one or more diffractive optical elements (DOEs).

In another embodiment, the light source or sources may be integrated or combined directly with a power source as an independent unit. Such an embodiment allows a light source to essentially operate on its own without any direct integration into the body's power source **104**. If the system does not require power for other system elements (besides light sources), then the use of such lights source/battery embodiments might eliminate the necessity for a body mounted power source **104**.

In another embodiment, the light source or sources may be coupled with one or more lenses that manipulate the light projections. Such manipulations can include, but are not limited to projection shaping or focusing and may incorporate DOEs.

In another embodiment, the system may contain and use mirrored or reflective surfaces to reorient the light projections in an optimal direction or directions. A light source may, for example, be mounted in such a way that the projection is not pointing in an optimal direction. In this case, a mirrored or reflective surface may be used to reflect the light projection in the optimal direction.

In another embodiment, one or more lights and/or one or more reflective surfaces may be combined with one or more beam splitters or a similar mechanism known in the art. Beam splitters are used to split a single beam of light into two or more beams. An example of such an embodiment includes the use of a single laser projection that is split into two or more projections (FIG. **8**).

In another embodiment, the directions of the projected light or lights are fixed with respect to the drill bit **157**. Conversely, in another embodiment, the directions of the projected light or lights are adjustable with respect to the drill bit **157** and/or work surface **205** (see, for example, FIG. **12**).

In another embodiment, the mounting position of the light source may be adjustable. Such adjustments may be horizontal with respect to the distance from the drill bit **157**, vertical with respect to the distance from the tip **259** of the drill bit **157**, or some combination thereof. Specifically, the horizontal position of one or more of the light sources can be adjusted on the body **105** such that the transverse distance of, for example, the second source of light **101** from the longitudinal axis **151** (and hence the distance of the second light source from the chuck **103** can be varied) thereby selectively varying the position of the second visible projection **121** on the work surface **250**; and with respect to FIGS. **5A** and **5B**, where the

vertical position or up/down position of the first light source **100** can be selectively varied with respect to the chuck **103**.

Any suitable mechanism can be used to aid positioning the light sources such as, but not limited to: slots, channels, and grooves, snap-ins wherein one or more light sources are snapped into predetermined locations on the body **105**, alone or in combination. For example, in FIG. 1B a slot **181** is shown whereby second light source **101** can be moved and selectively positioned. In FIG. 5A, a slot or channel **181** is shown attached to the chuck **103** as an aid for selectively positioning the first light source **100** with respect to the chuck **103**.

In one embodiment the first light source **100** produces a first light beam **110** at a 45 degree angle with respect to the longitudinal axis **151**. In this configuration of the invention either or both of the first and second light sources **100** and **101** are adjustable in terms of their position in order to selectively control the projection of the first and second light beams **110** and **111** with respect to a work surface **250**.

In another embodiment, the lights may be added and removed individually. This provides the user with a tremendous amount of flexibility with regards to system configuration and customization.

In another embodiment, the system has a single light source **100** or **101** that projects first and second visible projections **120** and **121** onto the work surface **250**. In this embodiment, the first and second visible projections **120** and **121** generate first and second rotating light projections **130** and **131**, which take the form of generate first and second concentric circle projections when the power drill **200** is aligned perpendicularly with respect to the work surface **250**. The first and second rotating light projections **130** and **131** can be used in conjunction with position and/or orientation of the drill bit **157** on the work surface **250** to visually align the drill **200** both vertically and horizontally with regards to the work surface **250**. For example, if the drill bit **157** is not essentially in the center of circular projection **130** produced by light source **100**, the drill bit is misaligned with reference to the work surface **250**.

#### Body Configurations

The system includes a body **105** on which at least some of the system elements are included.

Given the wide array of features and implementations offered by the system, the body **105** can take on a variety of shapes and sizes. Such shapes and sizes are often determined by factors such as: drill bit size, power drill physical form, chuck or cutting tool holder size and shape, light configurations, etc.

In one embodiment, the body **105** is simply a standard power drill chuck **103** with one or more light sources attached thereto. In this embodiment, the body itself **105** is the chuck or cutting tool holder **103**.

The body **105** can take any suitable form such as a disk such as, but not limited to, a transparent or partially transparent disk, preferably made from a light-weight, rigid, and strong material. It should be noted that a transparent body of some form is preferred (e.g., transparent plastic or substantially transparent when the body **105** is rotating), as it provides the greatest amount of work surface and drill bit visibility. In this embodiment, a chuck or cutting tool holder **103** is also normally included.

In another embodiment (FIG. 15), the body **105** or some other element of the system could be configured so that it produces an air current while rotating. This air current **161** or air flow would be essentially projected towards the work piece during drilling operations, and have the effect of blowing or pushing drill bit debris **162** away from the operating

drill bit and/or work surface **250**. Such air currents are advantageous to the power drill user as it allows them to better visualize the work surface and drill bit during drilling operations. In this embodiment, the elements that produce the air flow could be anything known in the art. This includes, but is not limited to airfoils **160**, surface projections, or other techniques that can create air currents that are generally projected in a specific direction. FIGS. 15 through 16B depict the use of airfoils **160** to create an air current **161** that pushes debris **162** away from the work surface **250**. The airfoils **160** can be fitted to the body **105** in all of the embodiments of the invention.

In another embodiment, the body **105** can either rotate in conjunction with the rotational portion of the rotary power tool or independently on its own. The later configuration allows the user to position the drill bit against the work surface and spin the body via a means other than that of the rotational force of the rotary power tool; this has the effect of producing circular projections on the work surface **250** without the need to engage the rotary power tool. This can be advantageous for a rotary power tool user since they can evaluate and correct for work surface misalignment prior to and without the need to begin boring operations. In one embodiment, the body can spin independently via a manual means. In another embodiment, an independent integrated rotational force such as an electric motor or wind-up engine can be utilized to rotate or spin the body without the necessity of engaging the rotary power tool.

#### Mounting and Chucking

The system can be mounted to the rotating portion of a power drill in a variety of ways. The system can be further implemented as either a permanent part of the tool or as an attachment to the tool.

In one embodiment related to mounting, the system is connected to the drill through a standard means known in the art. This includes, but is not limited to a shaft **106** that attaches to the power drill's existing chuck, a standard chuck socket that attaches to the power drill's rotating output shaft (thus replacing the drill's chuck), or a quick change chuck mechanism like those offered by San Ou Machinery Limited Company of Zhejiang China.

The system can also provide a means of locking the drill bit or cutting tool into the rotating system. This can be done through a variety of methods known in the art, including but not limited to the integration of a chuck **103** into the system, e.g., a mechanism such as the Craftsman Speed-Lok® Quick Connector.

In another embodiment related to mounting, the system is connected to the drill by a chuck attachment mechanism. Such a mechanism attaches to some portion of the power drill's existing chuck **103** without interfering with the rotational operation of the chuck **103** or the drill bit **157**.

In yet another embodiment related to mounting, the system is attached to the drill bit **157**. In this embodiment, the system is attached in such a way as to not interfere with the rotational operation of the chuck **103** or the drill bit **157**.

#### Power

The system can use a variety of power sources. These power sources provide electricity for the lights and any other associated electrical components.

In the one embodiment, the power source **104** is one or more batteries that are integrated in the system. The batteries may be any type known in the art, including but not limited to disposable or rechargeable batteries. The batteries may be mounted on or in the body in a variety of positions. In another embodiment, the power source may be the electrical source of the power drill itself. In yet another embodiment, power may

## US 7,992,311 B2

11

be obtained by converting the kinetic energy (obtained from the rotation of the system) into electricity.

In one embodiment, the entire system can be powered on and off via a single power switch. In another embodiment, the system functions can be powered on and off in groups via a single switch.

In another embodiment, the system may contain two or more switches that control individual system elements or groups of system elements. An example could be a set of power switches that individually control a group of lights that are used for a specific purpose, such as a configuration for visual work surface alignment (light sources **100** and **101**) versus a configuration for visual drill bit or cutting tool work surface positioning light sources **101** and **102**.

In another embodiment, the system can be automatically turned on by movement or rotation, and/or automatically turned off by some period of non-movement or inactivity.

In another embodiment, the light source mounting positions are configured so light power is easily obtained through the built-in connectors.

In another embodiment, each light source may be integrated or combined directly with a power source as an independent unit. Such an embodiment allows a light source to essentially operate on its own without any direct integration into or need for a body-mounted power source.

Informational Feedback

The system may also provide some sort of informational display or feedback for the user. Such feedback could be visual, audible, or tactile in nature. The information supplied to the user could include, but is not limited to elements such as rotational direction (forward or reverse), rotational RPMs, drill bit temperature, sensor-based visualization, microwave or other types of imaging, etc.

In one embodiment, the display could be as simple as an LCD that can be seen when the Drill Guide is not rotating. In another embodiment, the display could be a Persistence of Vision (POV) system that can actually display text and/or graphics during rotation of the system (see FIG. 13). The POV display is pictured as a series of 7 LEDs lights **150**, but may be anything known in the art.

In yet another embodiment, the display can be projected onto a work surface **250**.

In another embodiment, the informational display can be implemented as a stand-alone system. FIG. 18 depicts an example of this embodiment that includes a Persistence of Vision (POV) system **150** on a body **105** that is devoid of the first and second light sources **100** and **101**.

Microcontroller, Sensor, and/or IC Integration

In one embodiment (FIG. 13), the system includes an accelerometer **1511** sensor or other rotational sensor that can measure the rotational characteristics of the system. In another example (FIG. 16), the system uses an inertial motion sensor **153** as a means of automatically turning the power on and off. In another example (FIG. 13), the system may combine one or more sensors or electronic components with a microcontroller **152** or other computing unit such as a computer processor. This computing unit could be used to add variety of features known in the art. These could include, but are not limited to, enhancing the capabilities of the sensor (or sensors), driving a user feedback or display system, regulating and managing the power system, turning the light sources on and off, etc.

The system may contain other sensors that are used for sub-surface visualization. Examples include the use of microwave sensors, thermal imaging sensors or functionally equivalent sensors to detect sub-surface obstructions or drill-bit positioning reference elements (located underneath the

12

work surface). Such sensors could be integrated with the system's body **105**, power source **104**, microcontroller **152** or computing unit, and informational feedback elements.

In another embodiment, the one or more sensors, one or more microcontrollers, or one or more ICs, can be implemented as a stand-alone system. FIG. 19 depicts an example of this embodiment that includes a Persistence of Vision (POV) system **150** on a body **105** with an accelerometer **1511** and a microcontroller **152** that is devoid of the light sources **100** and **101**.

Counter Balancing

Since rotary power tools typically operate in the 0 to 3000+ RPM range, the system will need to be properly balanced for stable rotation on the tool. The system may accomplish this in several ways.

In one embodiment, the system elements are distributed throughout the body in a generally balanced manner so that the ad-hoc adjustment or addition of lights is generally offset by the static weight distribution of the body **105**, chuck or cutting tool holder **103**, and power source **104**.

In another embodiment, the power source location may be altered to offset the ad-hoc adjustment or addition of light sources.

In another embodiment (FIG. 17), the body may include or provide for the ability to add counter weights **115** that can be used to offset the ad-hoc adjustment or addition of lights. Slots or channels **181** (labeled as **181a** through **181d** in FIG. 17) can be used to move the counter weights **115** about the top **109** or bottom **117** surface of the body **105**; in FIG. 17 the slots or channels are labeled as **181a** through **181b**.

In yet another embodiment, the body contains a mechanism for dynamic counter-balancing. In this configuration, any ad-hoc adjustment or addition of light sources is automatically offset by one or more counter-balance mechanisms.

An operator could choose to use the invention merely as an alignment system and ignore the depth indication system aspects of the invention. This embodiment can apply to a rotary boring tool (such as, but not limited to: a power drill **200** or a stationary drill press or a smaller Dremel® drill tool) having a rotatable drill bit **157**, wherein the drill bit **157** is attached to a cutting-tool holder such as a chuck **103**, the tool having a longitudinal axis **151**, wherein the tool is used to drill holes in a work surface **250** of a work piece **249**, comprising:

first and second light sources **100** and **101**; and

a body **105** for operably coupling the first and second light sources **100** and **101** to the cutting-tool holder such that the first and second light sources **100** and **101** are located in the same transverse plane with respect to the longitudinal axis, wherein the first and second light sources **100** and **101** respectively produce first and second light beams **110** and **111**, wherein the second light beam **111** is projected parallel to the longitudinal axis, wherein during normal operation of the alignment system the first and second light beams **110** and **111** combine with a work surface **250** to create a 45°-45°-90° right angle triangle,

whereupon operation of the rotary boring tool and when the rotary boring tool is held perpendicular to a work surface **250** of a work piece **249** the first and second beams of light **110** and **111** project inner and outer concentric circles **130** and **131** of light onto the work surface **250** thereby confirming that the rotary boring tool is being held at a perpendicular angle with respect to the work surface **250**,

wherein the first and second light sources **100** and **101** are positioned on the same side of the cutting-tool holder as

## US 7,992,311 B2

13

depicted, for example, in FIG. 5A or on opposite sides of the cutting-tool holder as depicted, for example, in FIG. 1A, and

wherein this embodiment may include airfoils 160 coupled to the body 105 for moving drill debris away from the work surface 250 while drilling into the work piece 249, as depicted, for example, in FIGS. 15 through 16B.

What is claimed:

1. An alignment and depth indication system with respect to a tool having a rotating means for rotating a drill bit, said rotating means having a longitudinal axis, comprising:

first and second light sources; and

a means for operably coupling said first and second light sources to said rotating means, whereby wherein said first and second light sources respectively produce first and second light beams, wherein said first light beam is projected at an adjustable acute angle with respect to said longitudinal axis, and said second light beam is projected parallel to said longitudinal axis,

whereupon rotation of said rotating means and when said rotating means is held perpendicular to a work surface of a work piece said first and second beams of light project inner and outer concentric circles of light on the work surface thereby confirming that the tool is being held at a perpendicular angle with respect to the work surface, wherein said acute angle can be selected such that said first light beam defines the outer concentric circle of light, and wherein the distance between the outer and inner circles of light corresponds to a desired drill depth, whereupon drilling into the work surface the desired drill depth is achieved when the outer concentric circle of light merges with the inner circle of light to produce a single circle of light on the work surface.

2. The alignment and depth indication system of claim 1, wherein said means for operably coupling said first and second light sources to said rotating means is a circular substantially transparent disk mounted transversely to said tool with respect to said longitudinal axis.

3. The alignment and depth indication system of claim 1, wherein said means for operably coupling said first and second light sources to said rotating means is a circular body of generally planar shape mounted symmetrically and transversely to said tool with respect to said longitudinal axis, said circular body having a top surface, wherein said first and second light sources are mounted on said top surface of said circular body, wherein at least one additional light source is mounted on said top surface of said body, wherein at least one of said additional light sources projects a light beam parallel to said longitudinal axis to provide the tool with at least two light beams parallel to said longitudinal axis such that with respect to a work piece having at least two features of interest a tool operator can manually rotating said circular body to line up parallel light beams with respect to at least two features of interest on the work piece to facilitate the tool operator in placing a drill bit at a desired point on the work piece.

4. The alignment and depth indication system of claim 1, wherein said means for operably coupling said first and second light sources to said rotating means is a disk having a means for producing air flow to blow drill bit debris away from the tool.

5. A tool having a rotating means for rotating a drill bit attached to a cutting-tool holder, said rotating means having a

14

longitudinal axis, wherein said tool is used to drill holes in a work surface of a work piece, said tool comprising:

first and second light sources; and

a means for operably coupling said first and second light sources to said rotating means such that said first and second light sources are located in the same transverse plane with respect to the longitudinal axis, wherein said first and second light sources respectively produce first and second light beams, wherein said second light beam is projected parallel to said longitudinal axis, wherein during normal operation of said alignment system the first and second light beams combine with a work surface to create a 45°-45°-90° right angle triangle, wherein said means for operably coupling said first and second light sources to said rotating means is a disk having a means for producing air flow to blow drill bit debris away from the tool, and

whereupon rotation of said rotating means and when said rotating means is held perpendicular to a work surface of a work piece said first and second beams of light project inner and outer concentric circles of light on the work surface thereby confirming that the tool is being held at a perpendicular angle with respect to the work surface.

6. The alignment and depth system of claim 5, wherein said first and second light sources are positioned on the same side of the cutting-tool holder, wherein said first light source is orientated such that said first light source is orientated to project said first light beam to at least partly avoid the drill bit.

7. The alignment and depth system of claim 5, wherein said first and second light sources are positioned on the same side of the cutting-tool holder.

8. The alignment and depth system of claim 5, wherein said first and second light sources are positioned on the same side of the cutting-tool holder, and wherein said cutting-tool holder is a chuck.

9. A tool having a rotating means for rotating a drill bit, said rotating means having a longitudinal axis, said tool comprising:

first and second light sources; and

a means for operably coupling said first and second light sources to said rotating means, whereby wherein said first and second light sources respectively produce first and second light beams, wherein said first light beam is projected at an acute angle with respect to said longitudinal axis, and said second light beam is projected parallel to said longitudinal axis,

whereupon rotation of said rotating means said first and second light beams project first and second circles of light on a work surface such that when the drill bit of the tool is perpendicular to the work surface the diameters of said first and second circles of light are equal in size and therefore overlap thereby confirming to an operator that the tool is drilling perpendicularly with respect to the work surface.

10. The alignment and depth indication system of claim 9, wherein said means for operably coupling said first and second light sources to said rotating means is a disk having a means for producing air flow to blow drill bit debris away from the tool.

\* \* \* \* \*